

# **SIM LAB**

## INSTRUCTION MANUAL

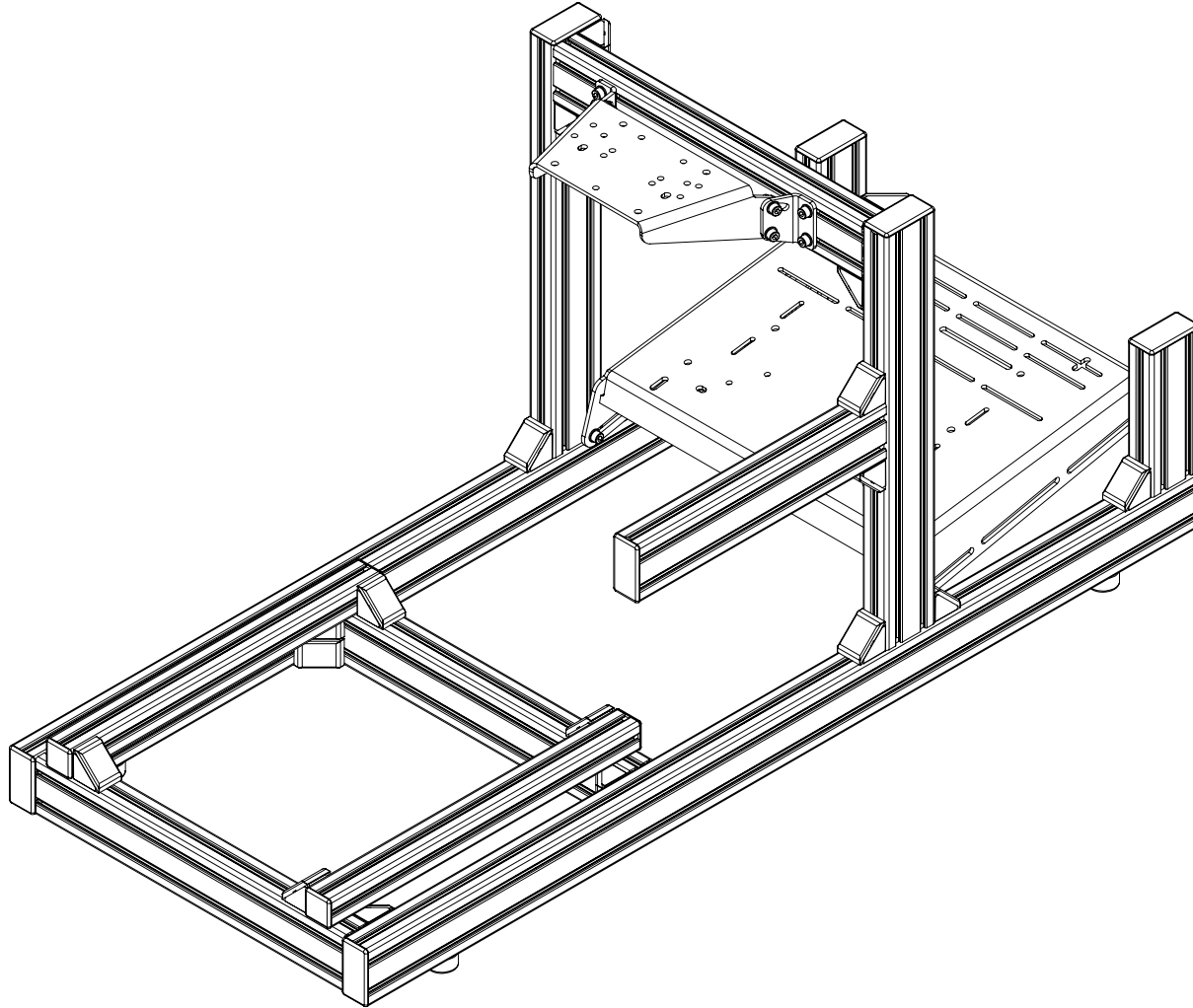

**GT1-EVO**  
**VERSION 2.3**  
Last updated: 21-03-2022

# BEFORE YOU START:

Thank you for purchasing this Sim-Lab product! On the following pages, you will find detailed instructions on assembly. This requires only a set of simple tools and some of your time. Please check the bill of materials before starting (page 22) and make sure all the parts are delivered.

Note:

Depending on your date of purchase, you may or may not have received a large bag of additional washers. If this is the case, use one on every M8 bolt to install brackets. This was a temporary solution and will be phased out as soon as possible and therefore is omitted from this instruction manual.

## Inserting Slot-Nuts:

You got excited, finished the build, put the caps on, but forgot to install one element. Do not worry. It happens to everyone. In this diagram, you can see how to insert a Slot-Nut directly into the slot from the side. You can also use one of your smaller Hex wrenches to help wiggle the Slot-Nut in place.

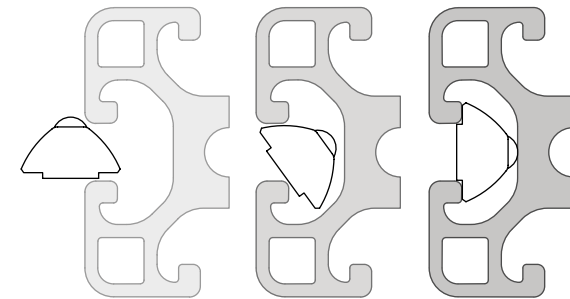

## Breaking tabs:

Sometimes tabs from corner brackets need to be broken off in order to fit as instructed. Place a flathead screwdriver behind the tab and tilt upwards.

Always make sure to point away from you while doing so. To know when to do this, we will show the following symbol  next to the brackets.

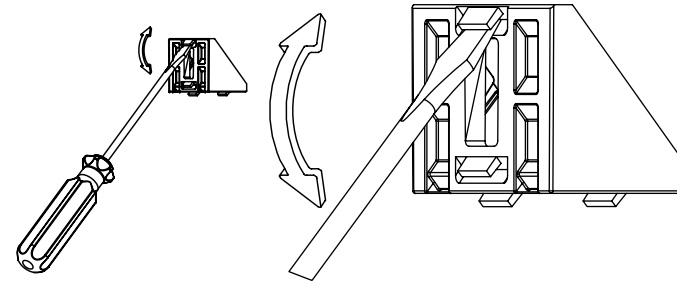

Tools needed:

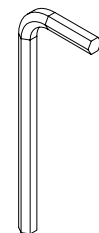

5/6MM



—

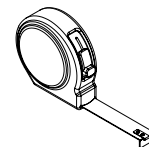
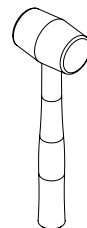

1350MM

Slot-Nut M8

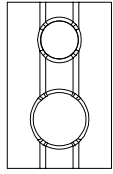
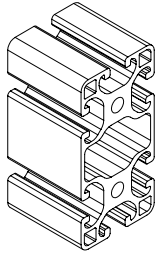

1X

4X

BUILD 2X

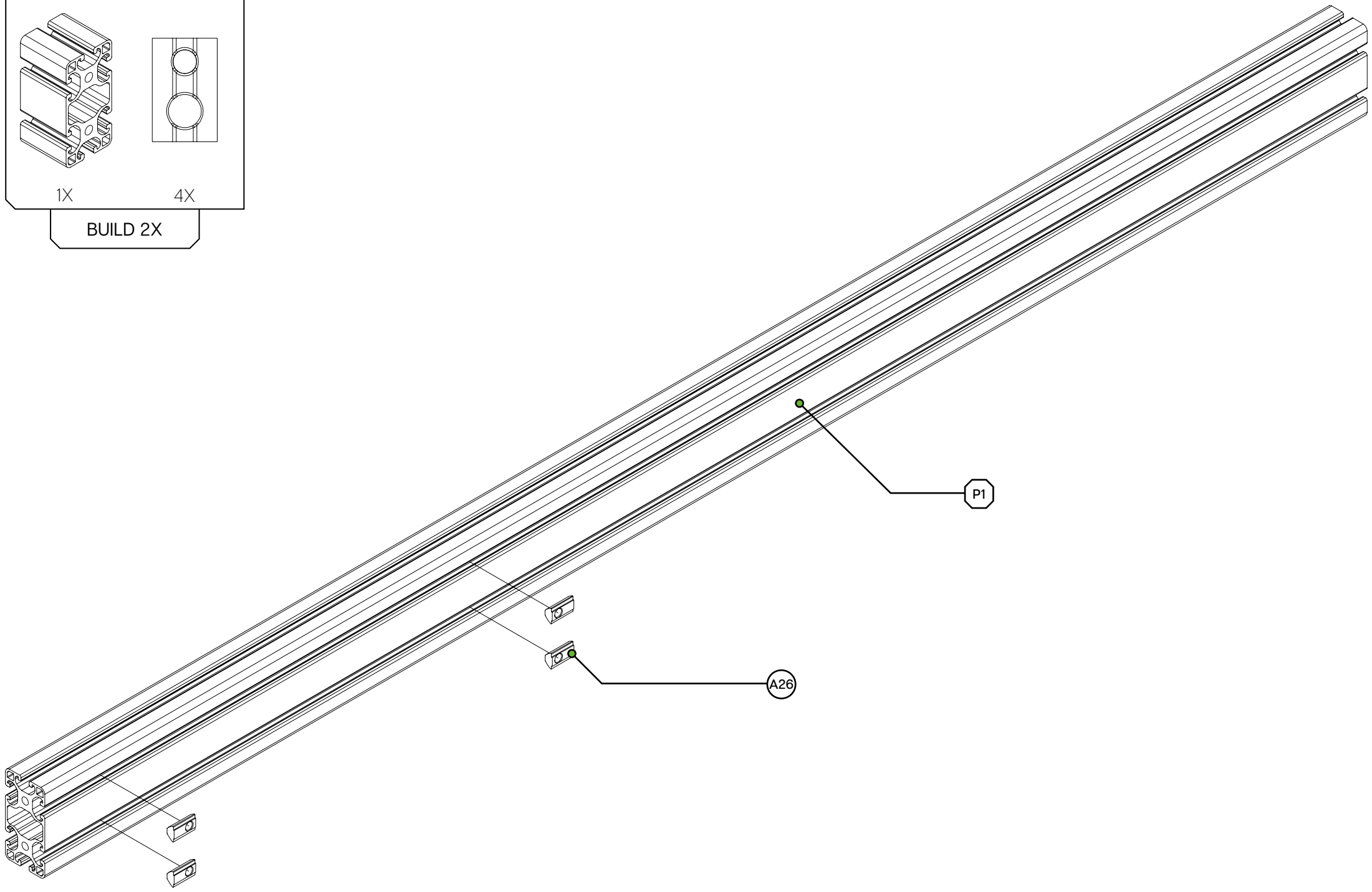

500MM Slot-Nut M8

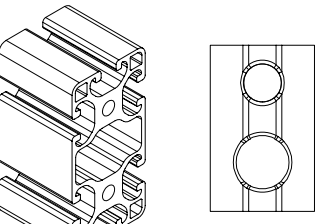

1X 4X

BUILD 2X

This inset box contains technical drawings of hardware. On the left, a 500mm slot-nut is shown in a perspective view, labeled '1X'. On the right, a slot-nut with two circular holes is shown in a top-down view, labeled '4X'. Below these drawings, the text 'BUILD 2X' is centered within a small rectangular frame.

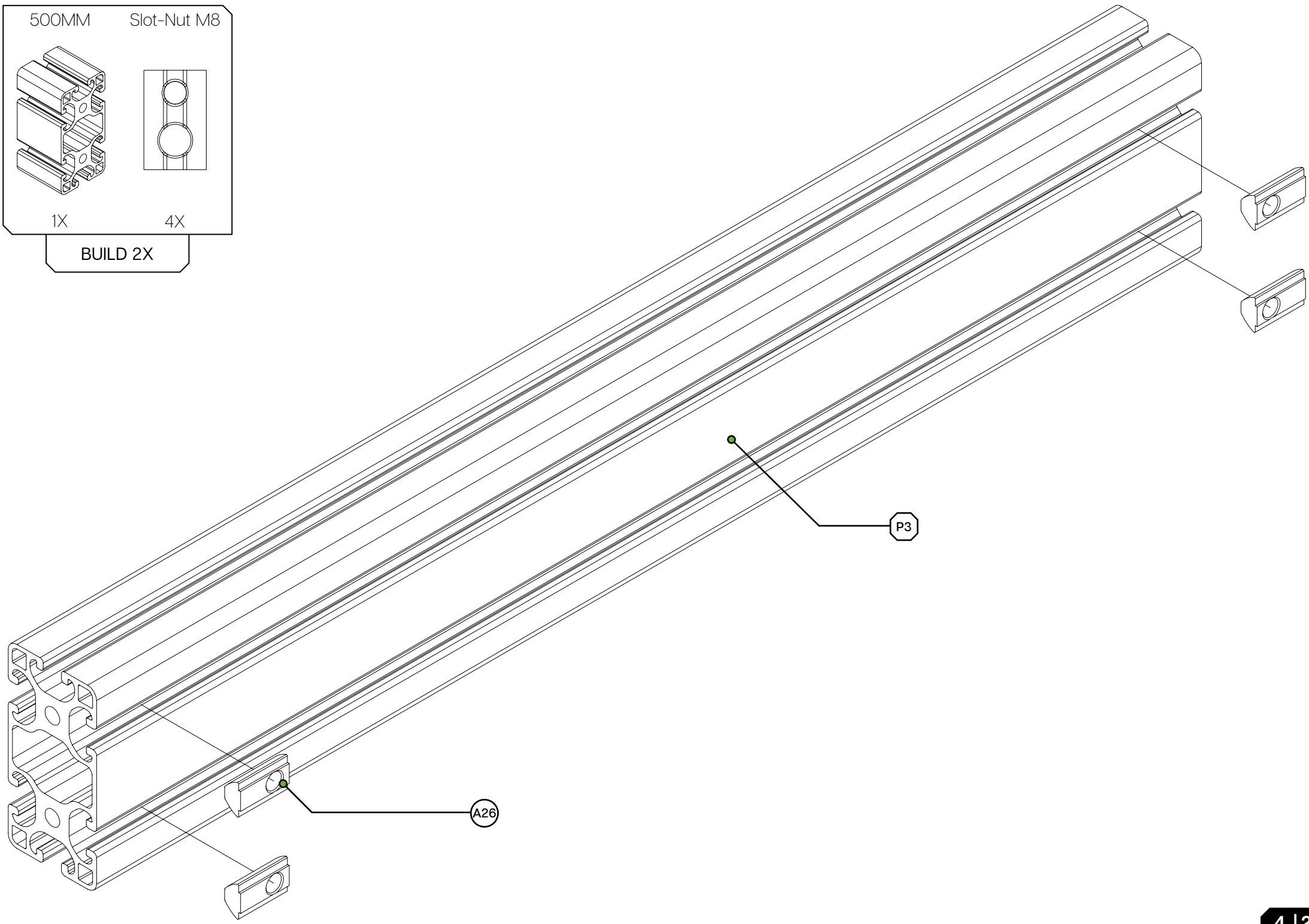

Corner Bracket

M8 X 16

8X

16X

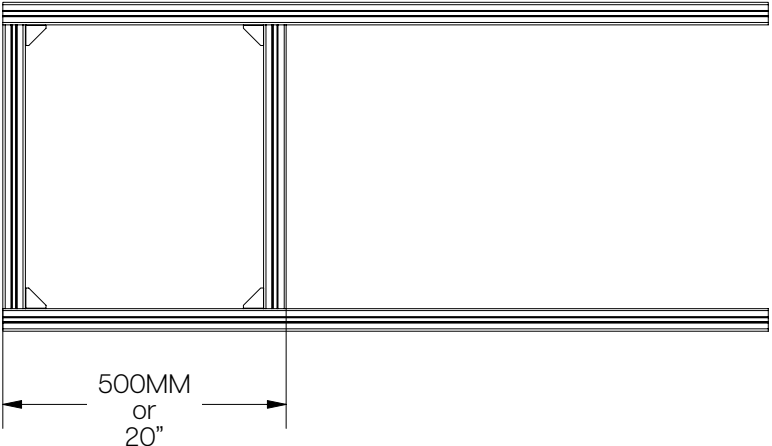
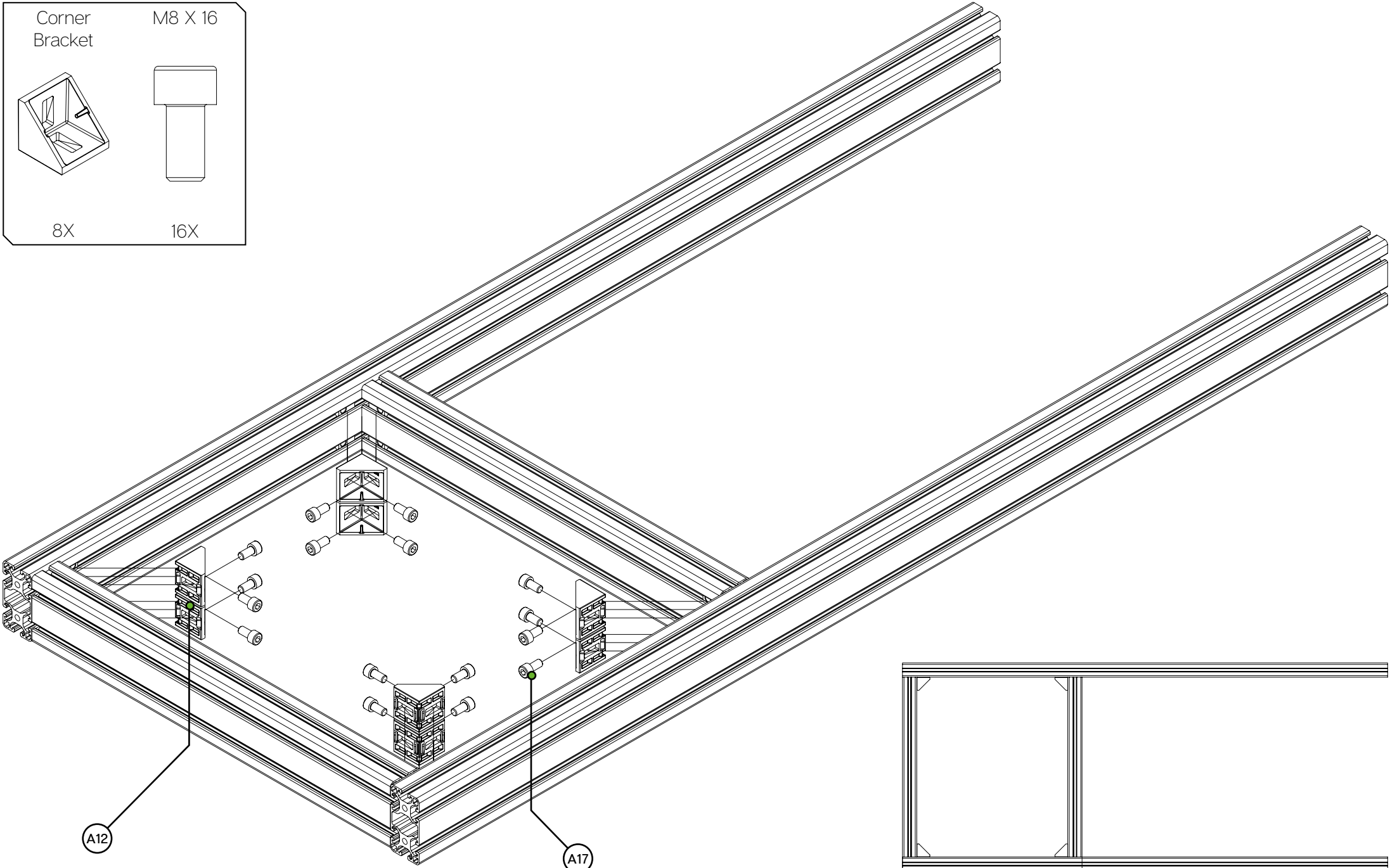

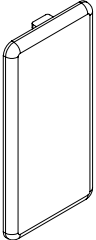
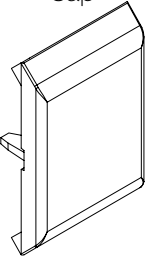
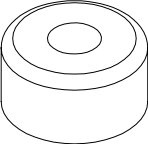
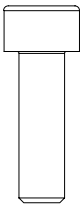
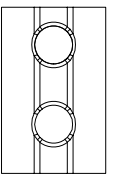
Profile 80x40 End-Cap	Corner Bracket Cap	Rubber Feet	M6 X 20 (A19)	Slot-Nut M6 (A27)
				
4X	8X	4X	4X	4X

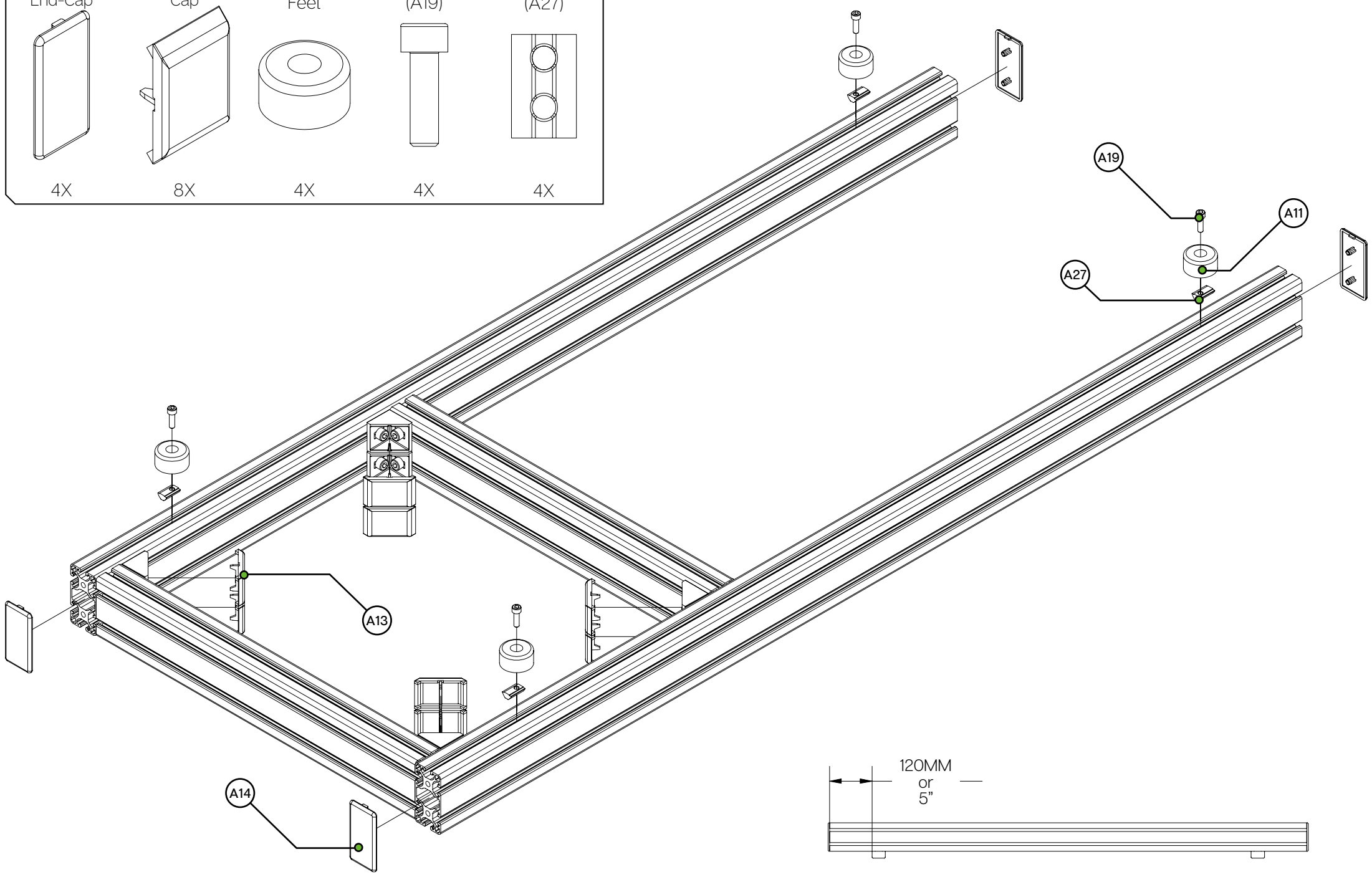

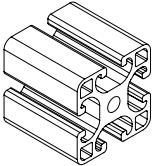
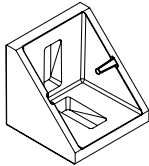
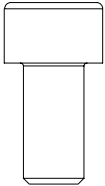
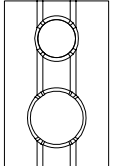
500MM	Corner Bracket*	M8 X 16	Slot-Nut M8
			
1X	2X	2X	2X
BUILD 2X			

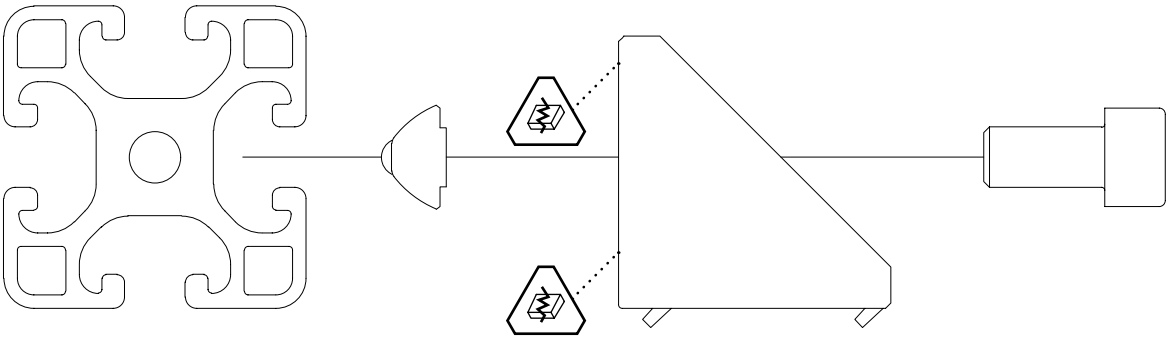
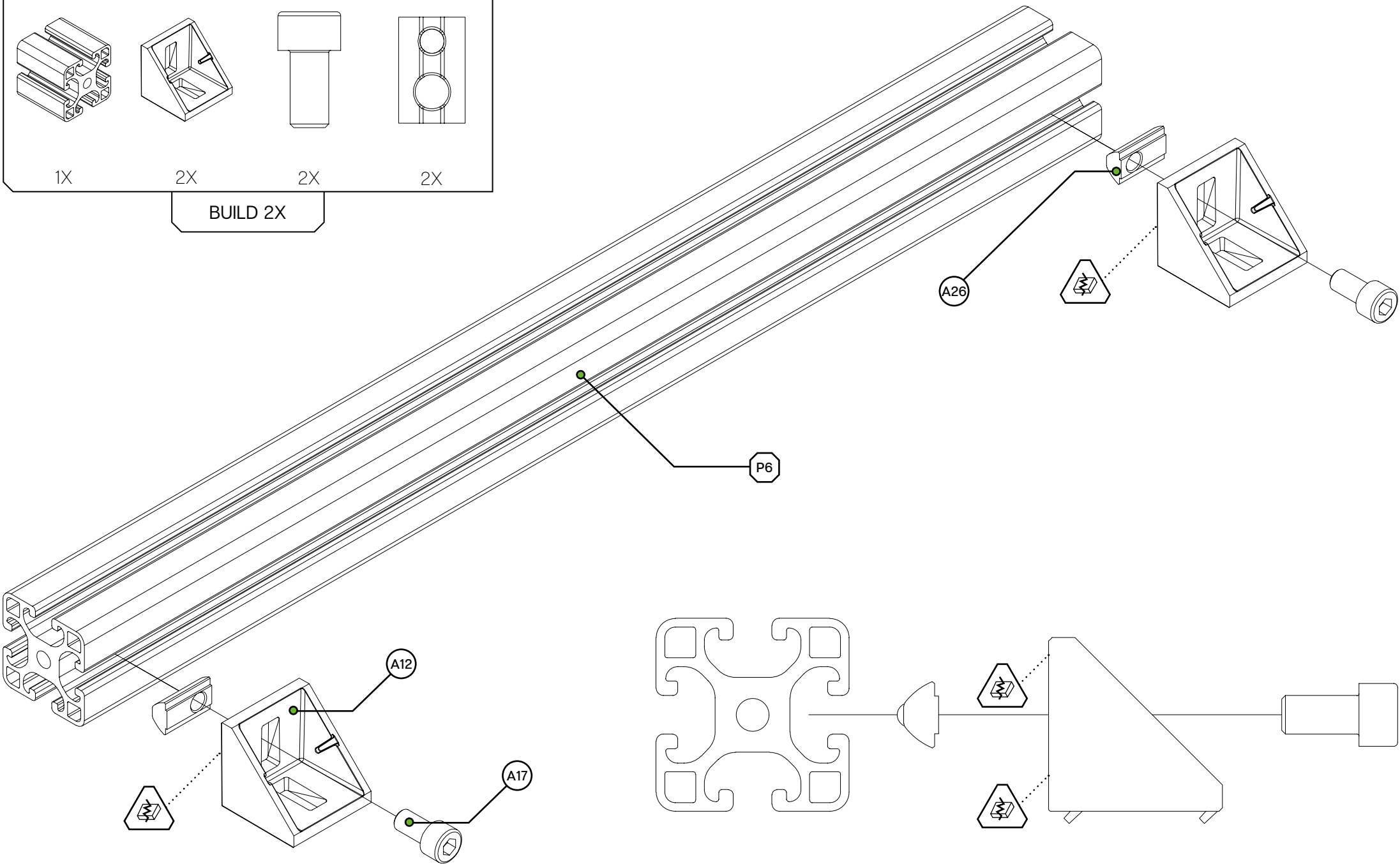

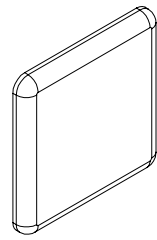
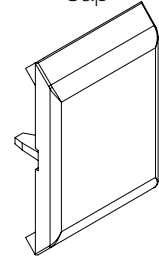
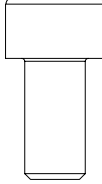
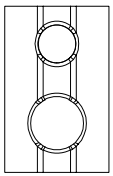
Profile 40X40 End-Cap	Corner Bracket Cap	M8 X 16	Slot-Nut M8
			
4X	4X	4X	4X

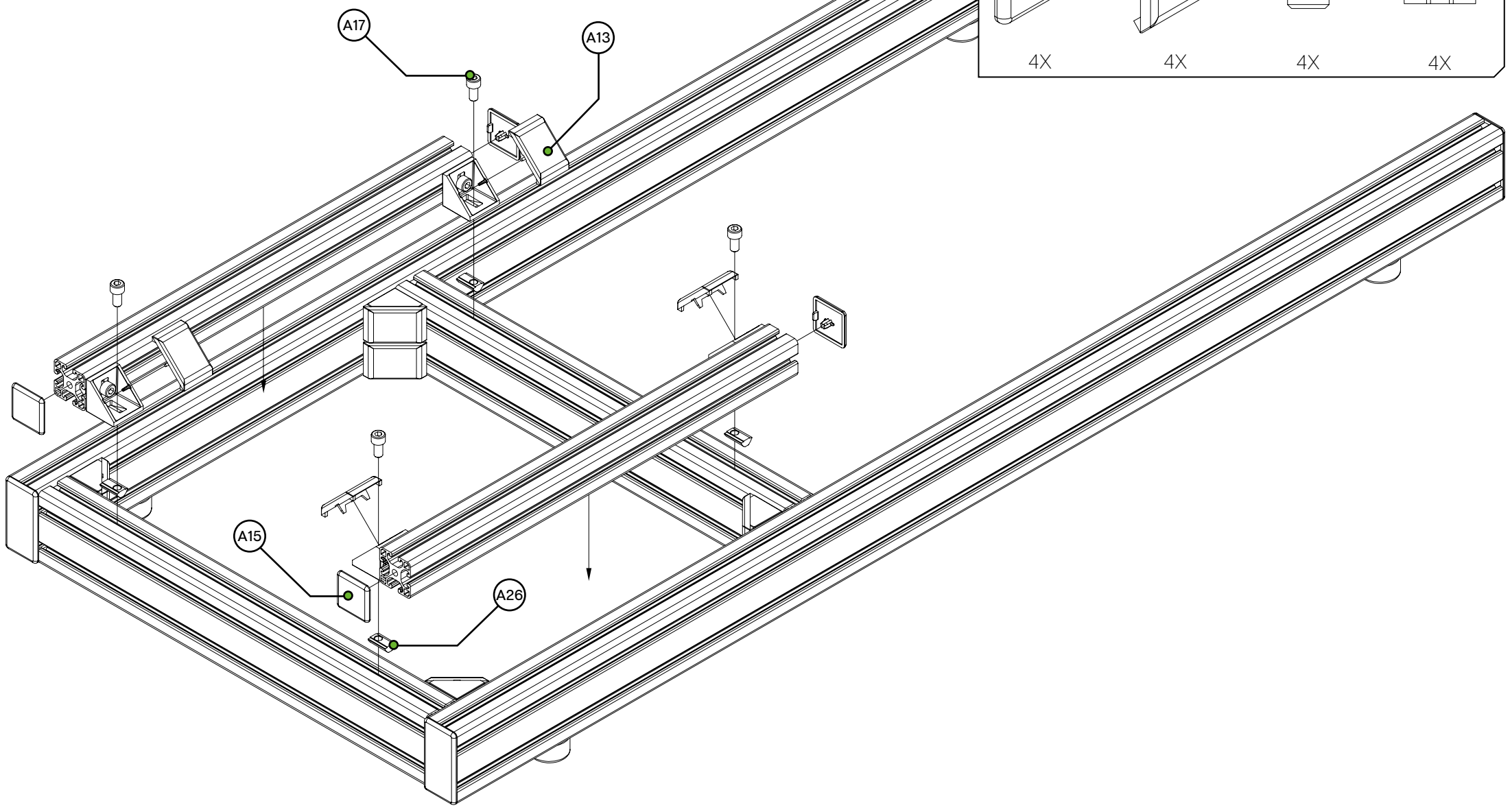

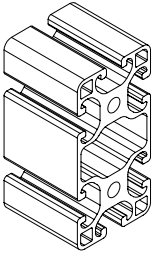
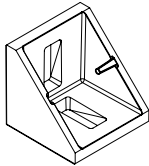
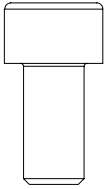
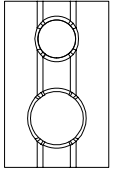

580MM	Corner Bracket	M8 X 16	Slot-Nut M8
			
1X	2X	2X	2X
BUILD 2X			

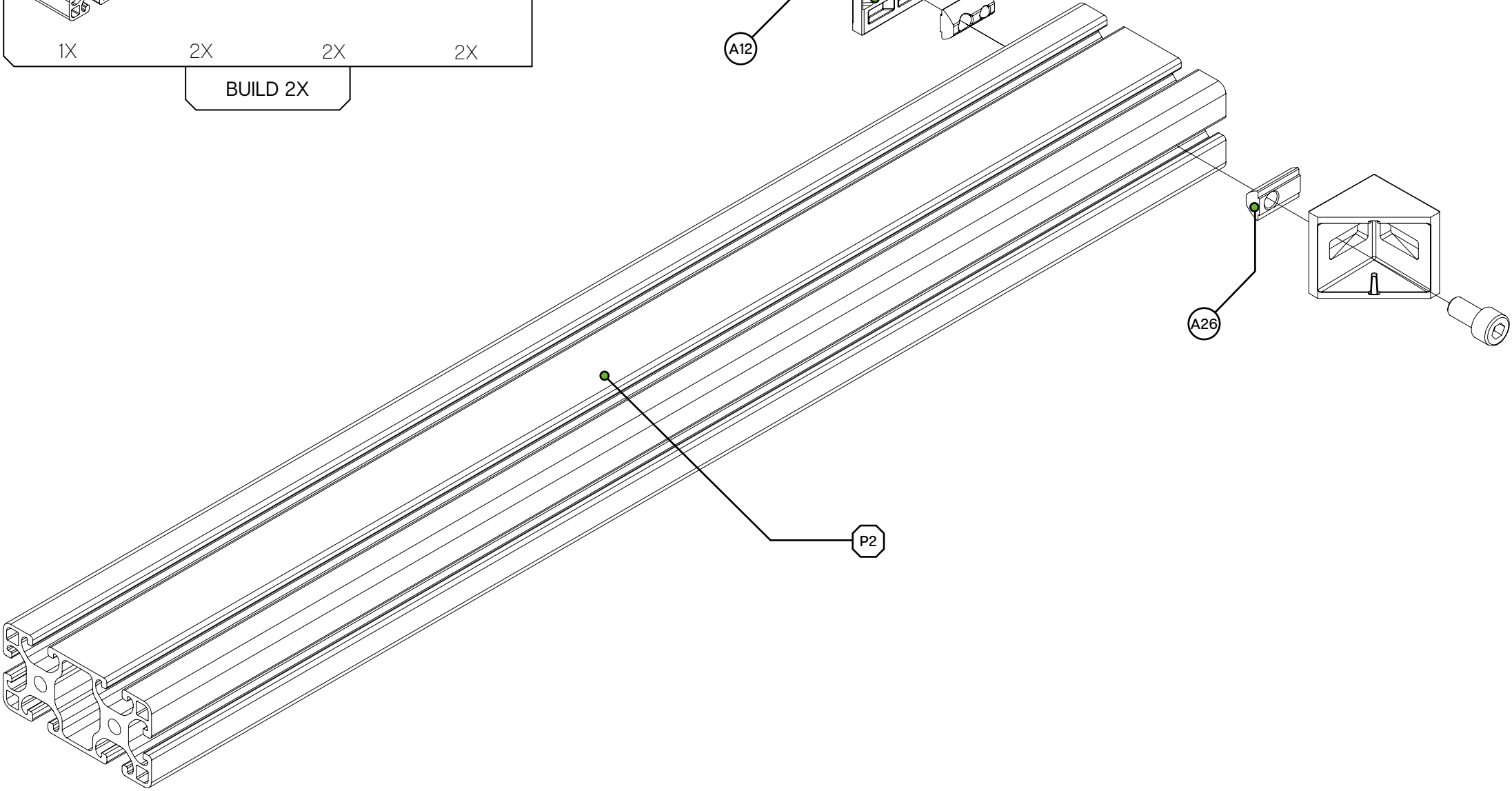
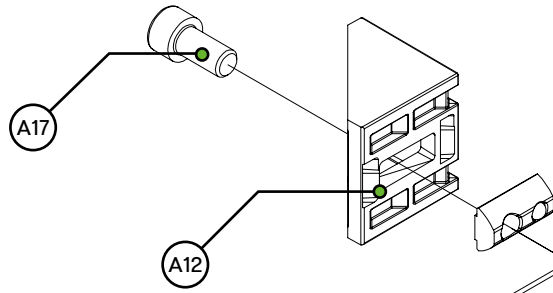

M8 X 16

Slot-Nut M8

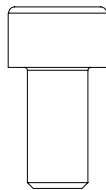

4X

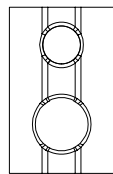

4X

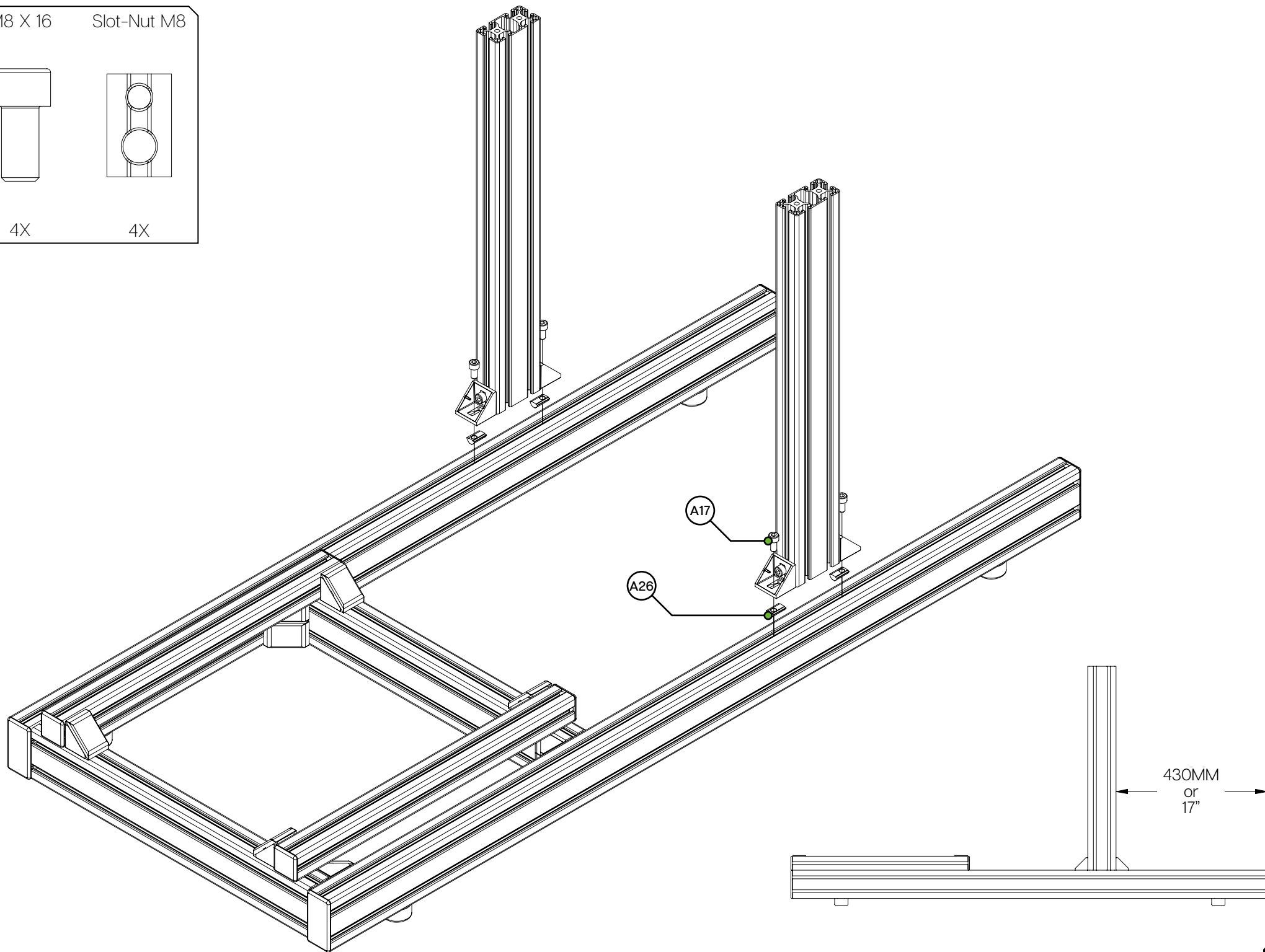

430MM  
or  
17"

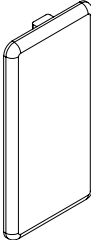
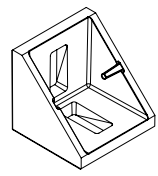
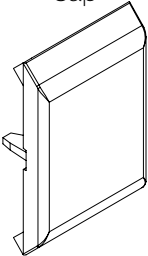
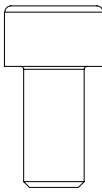
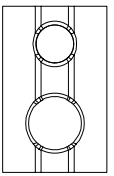
Profile 80X40 End-Cap	Corner Bracket	Corner Bracket Cap	M8 X 16	Slot-Nut M8
				
2X	2X	4X	2X	8X

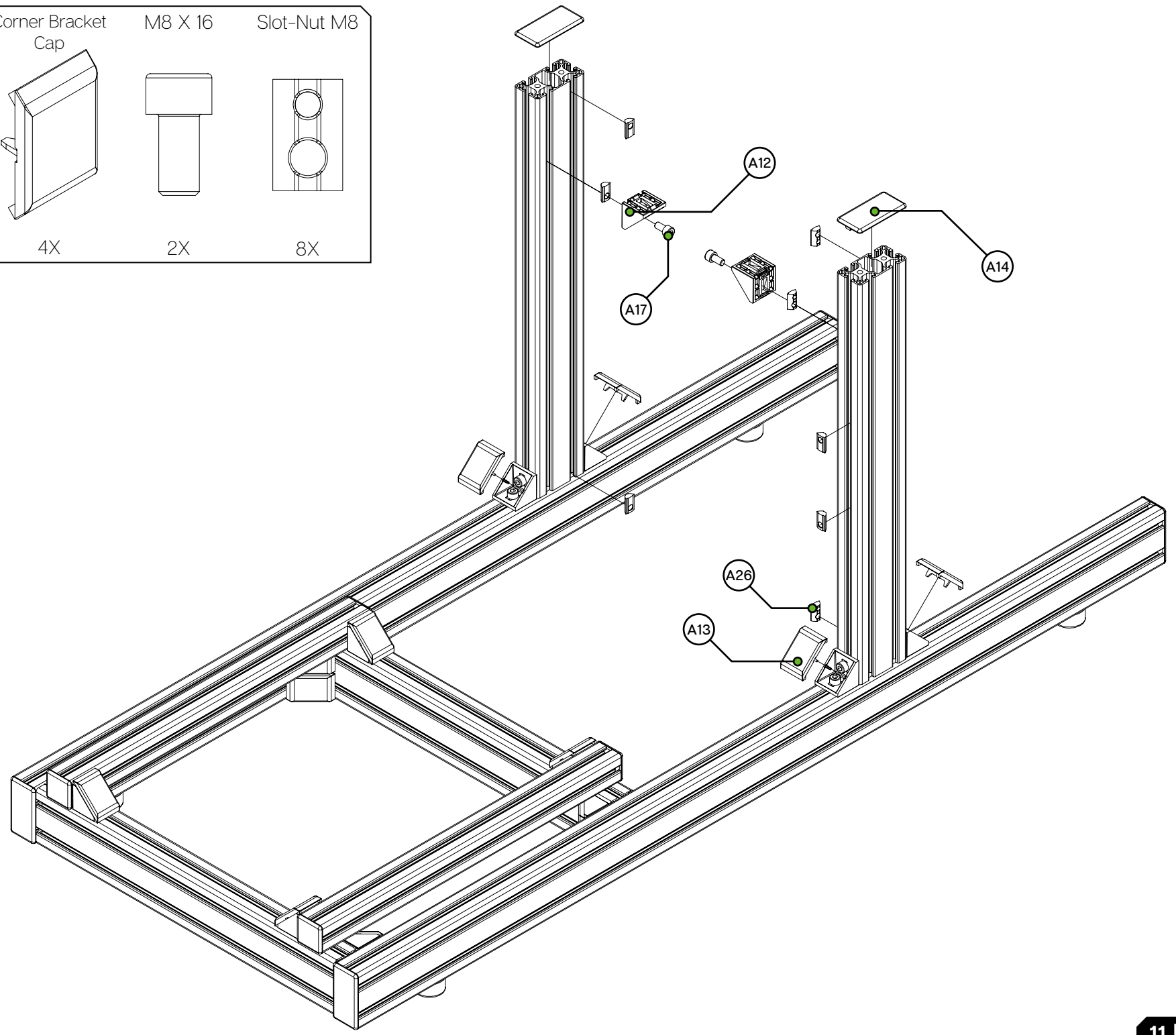

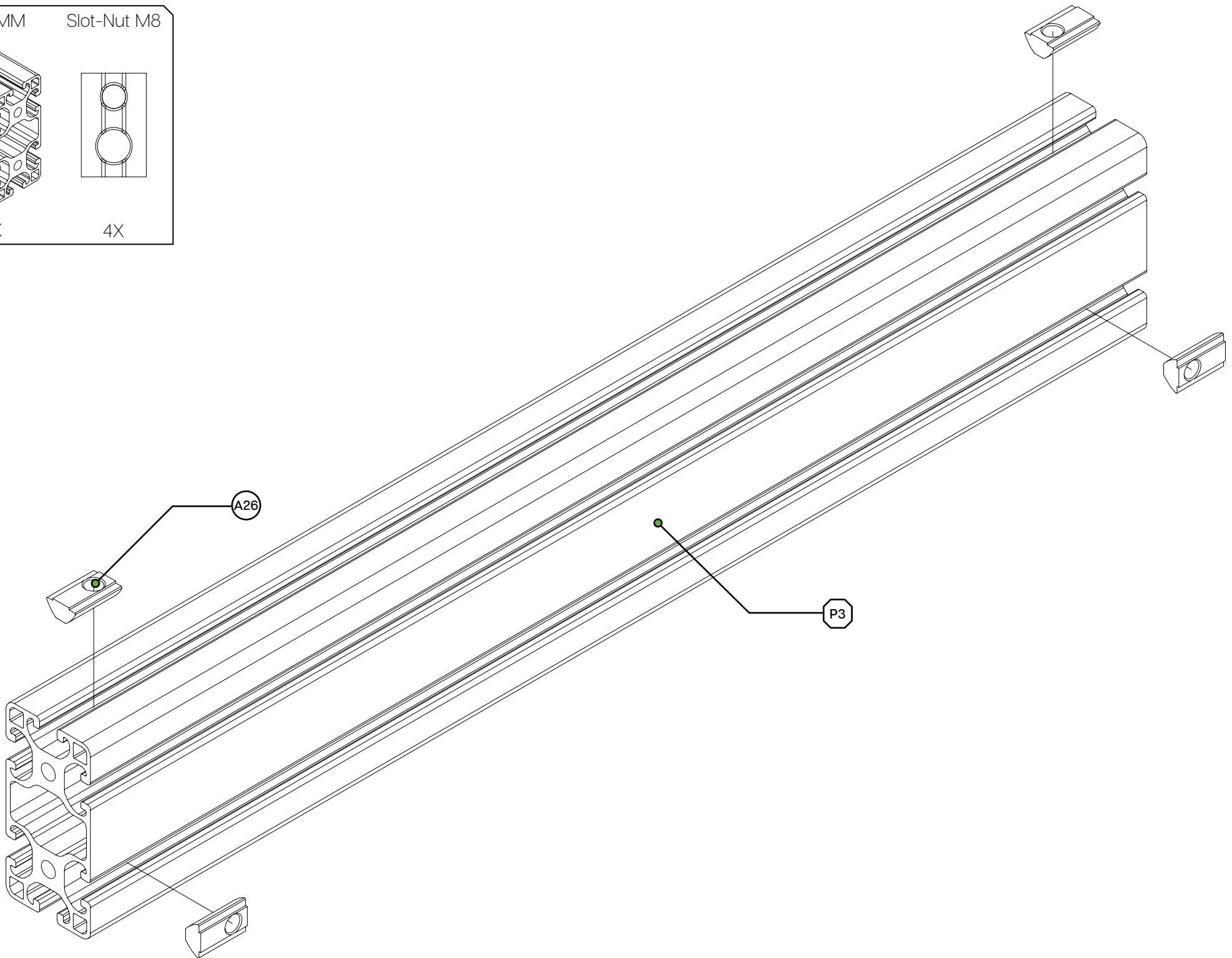
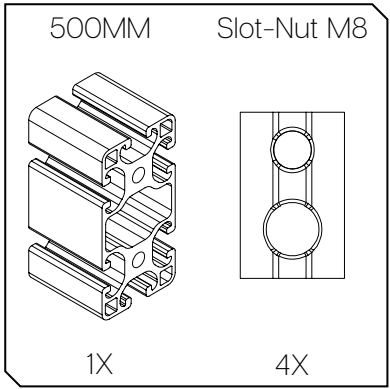

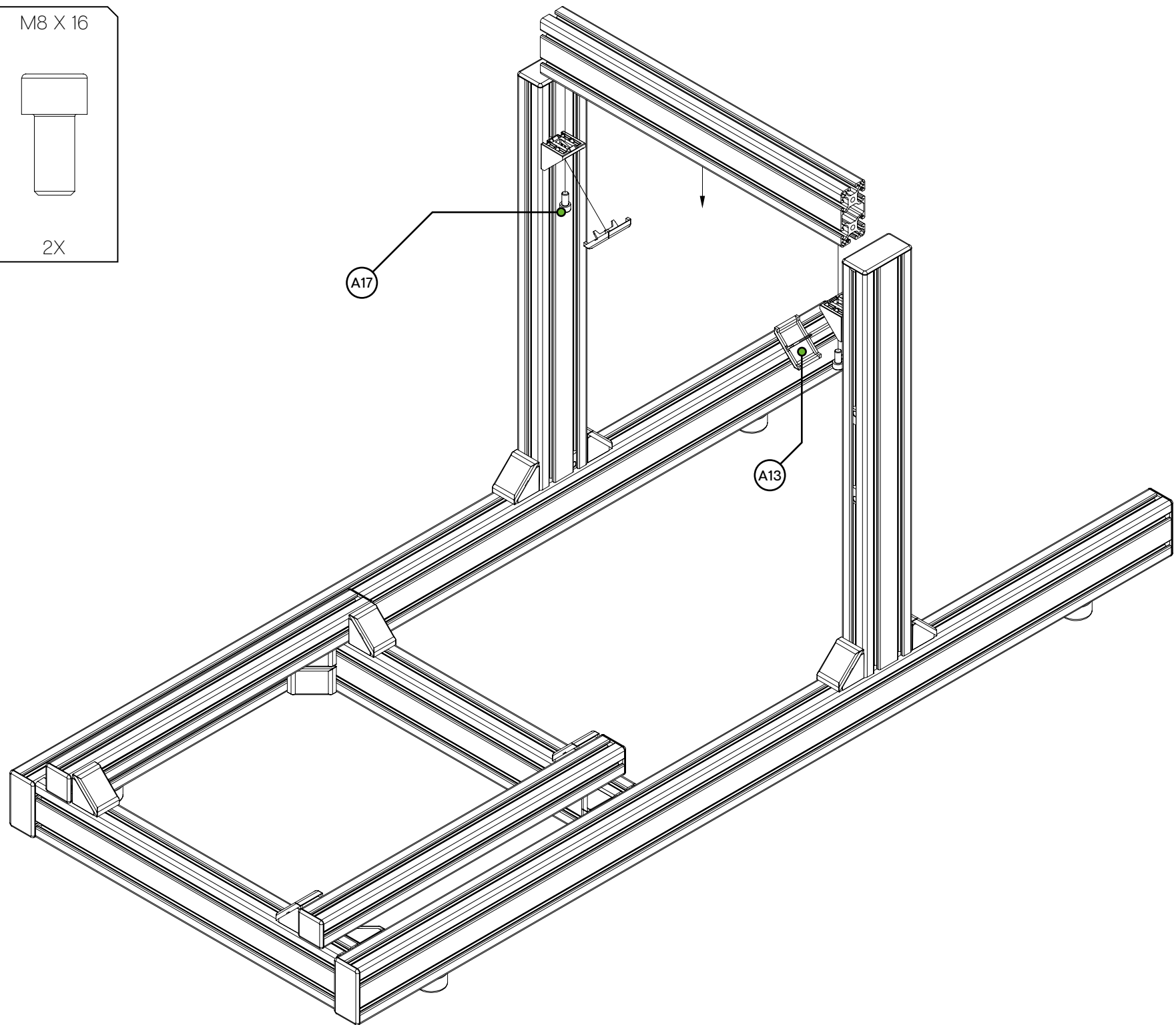
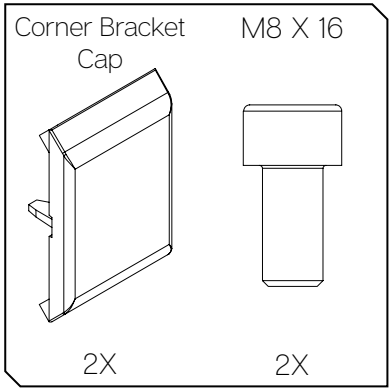

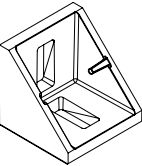
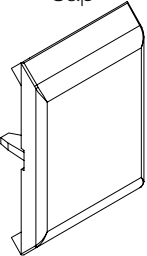
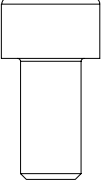
Corner Bracket*	Corner Bracket Cap	M8 X 16
		
2X	2X	4X

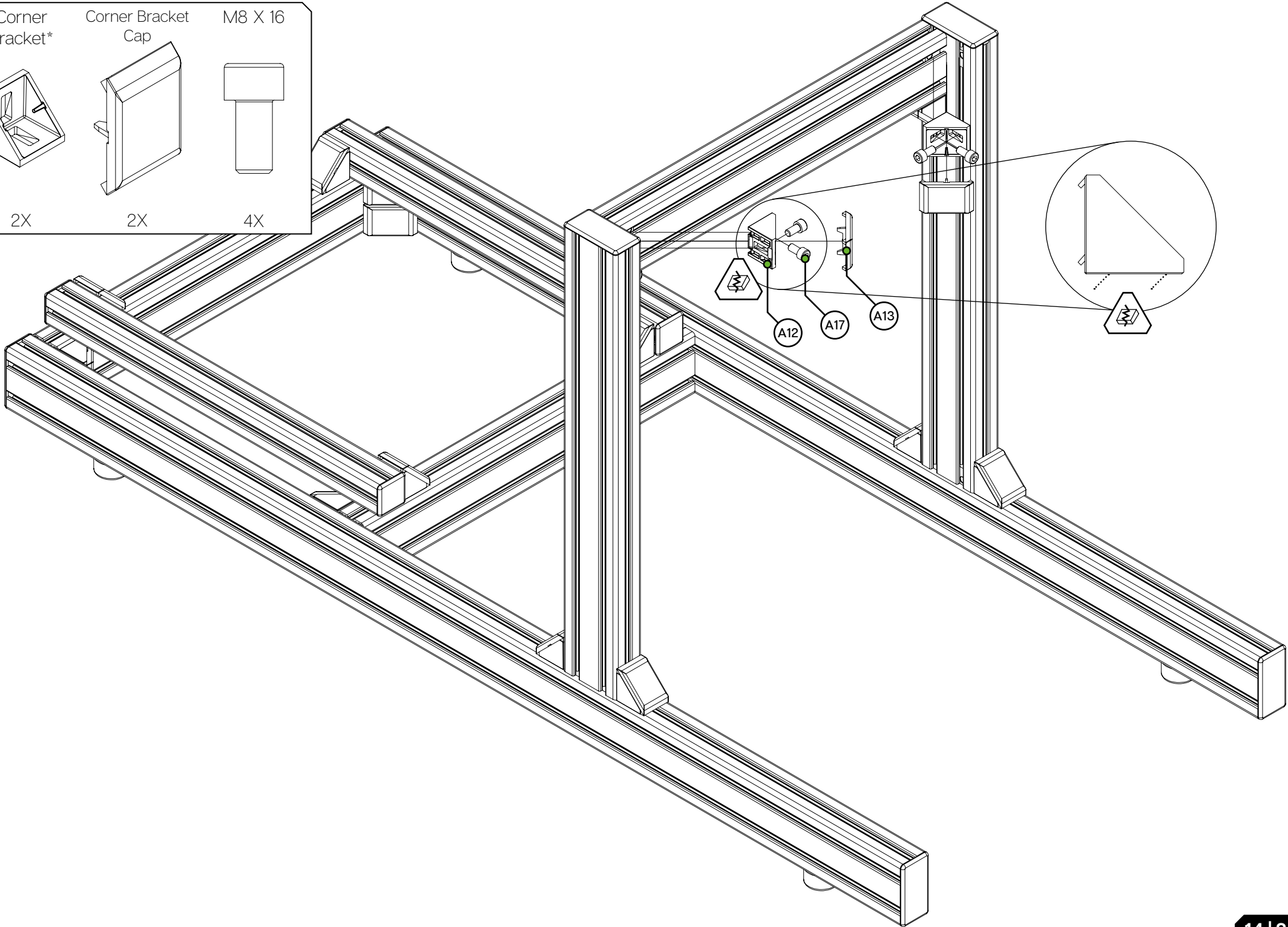

Wheel Deck

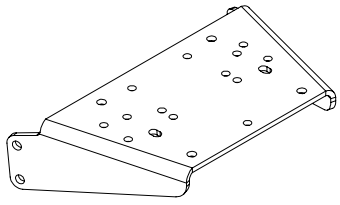

1X

Wheel Deck  
Pivot Plate  
Left (A9)

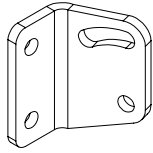

1X

Wheel Deck  
Pivot Plate  
Right (A10)



1X

M8 X 20

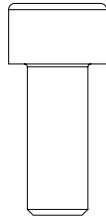

4X

Washer M8

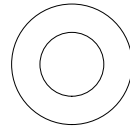

8X

Lock-Nut M8

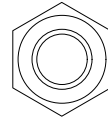

4X

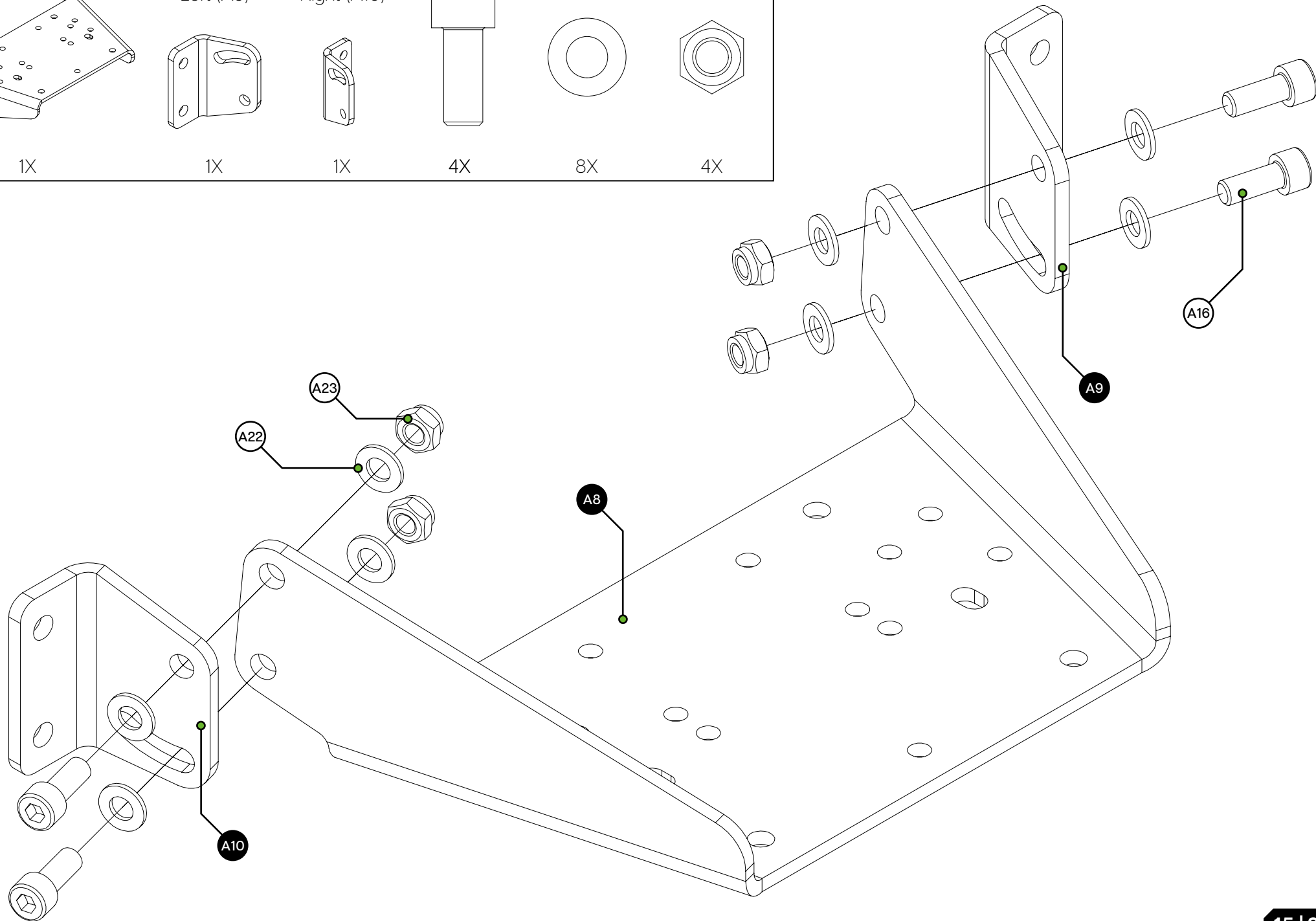

M8 X 16

Washer M8

Slot-Nut M8

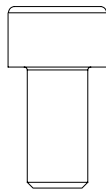

4X

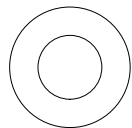

4X

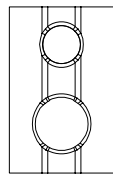

4X

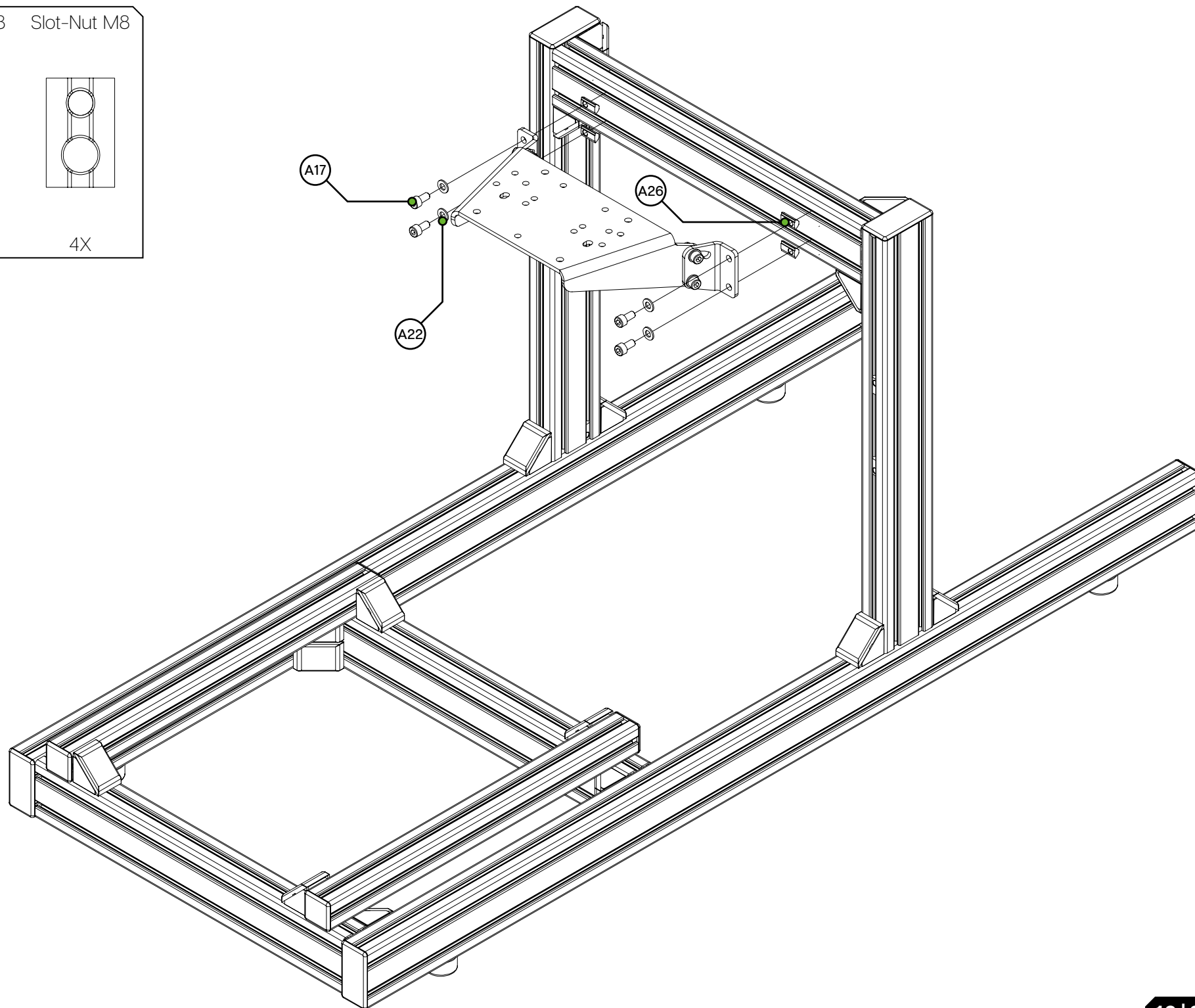



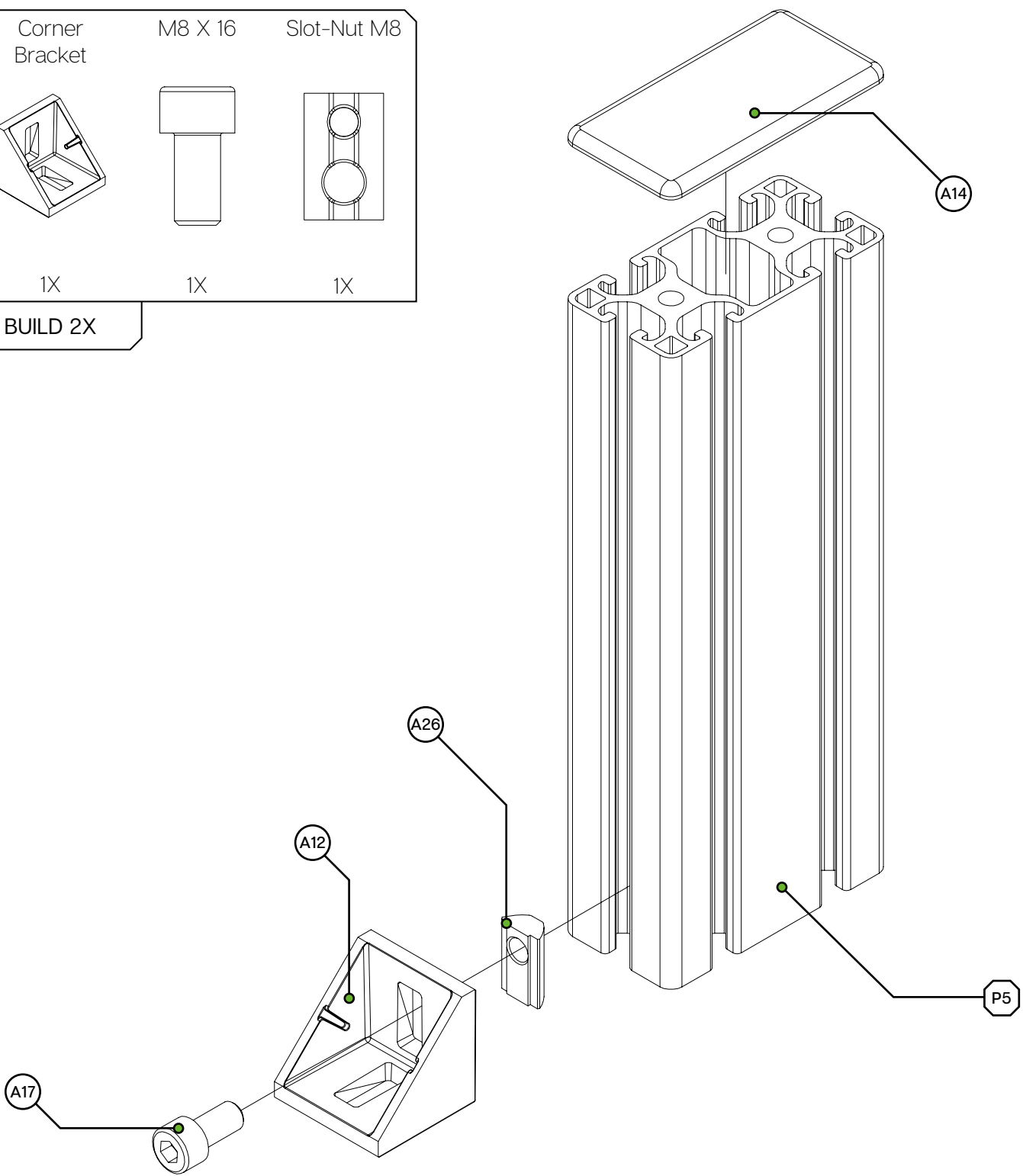
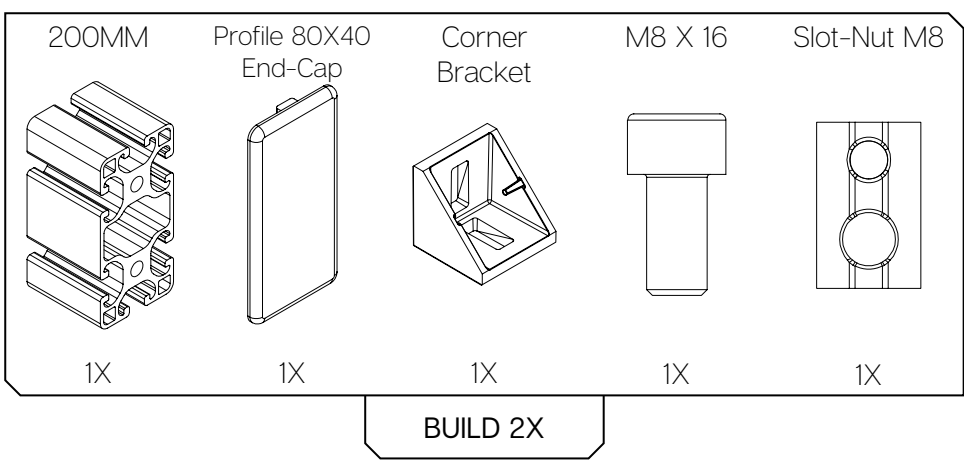

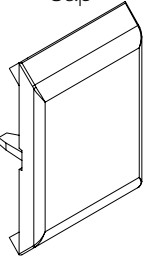
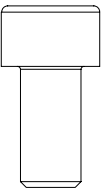
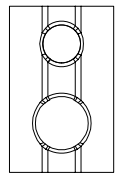
Corner Bracket Cap	M8 X 16	Slot-Nut M8
		
2X	2X	4X

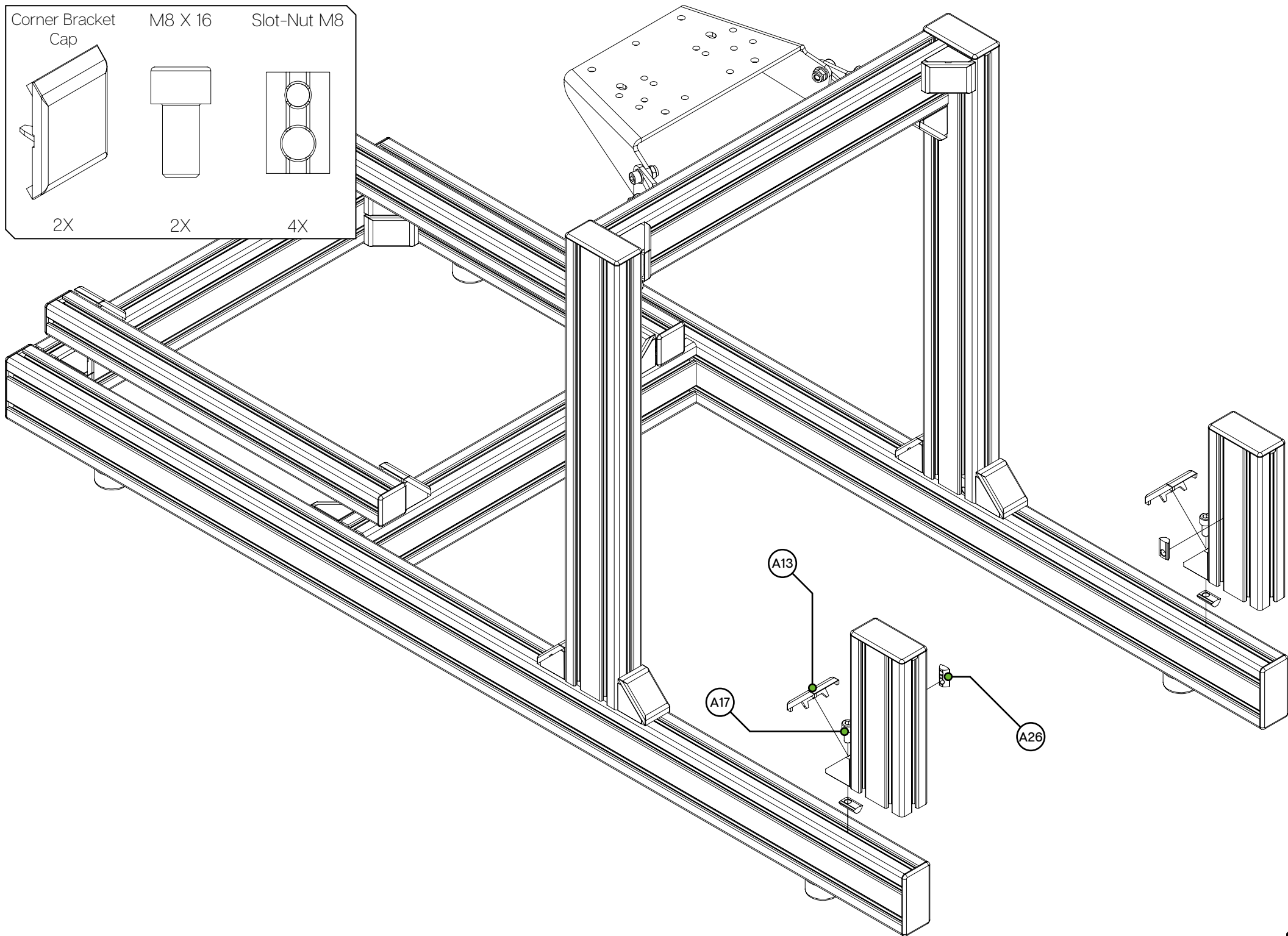

Pedal Deck

M8 X 16

Washer M8

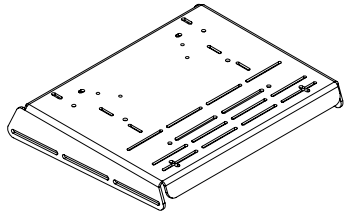

1X

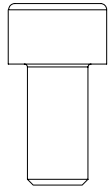

4X

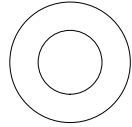

4X

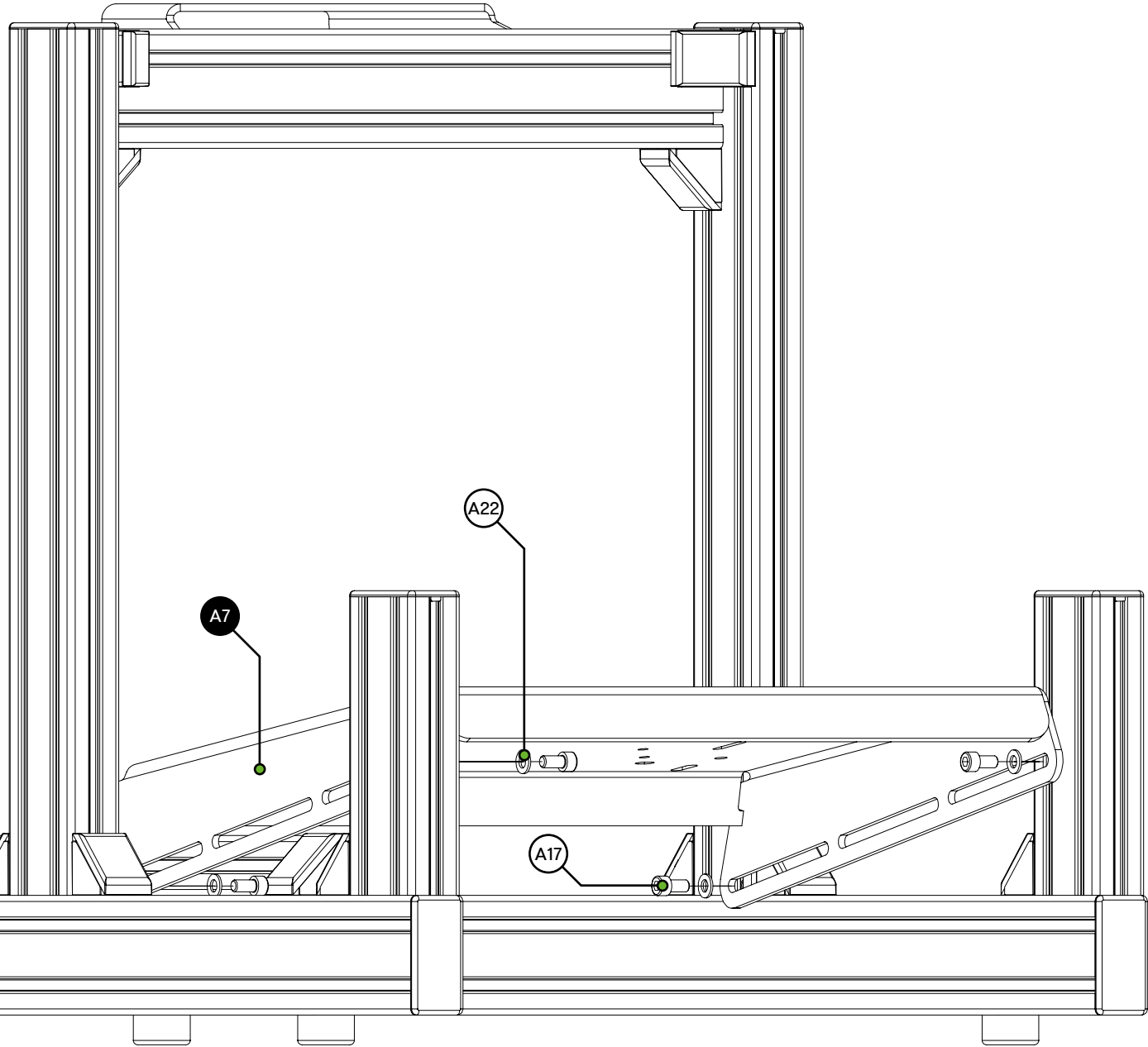

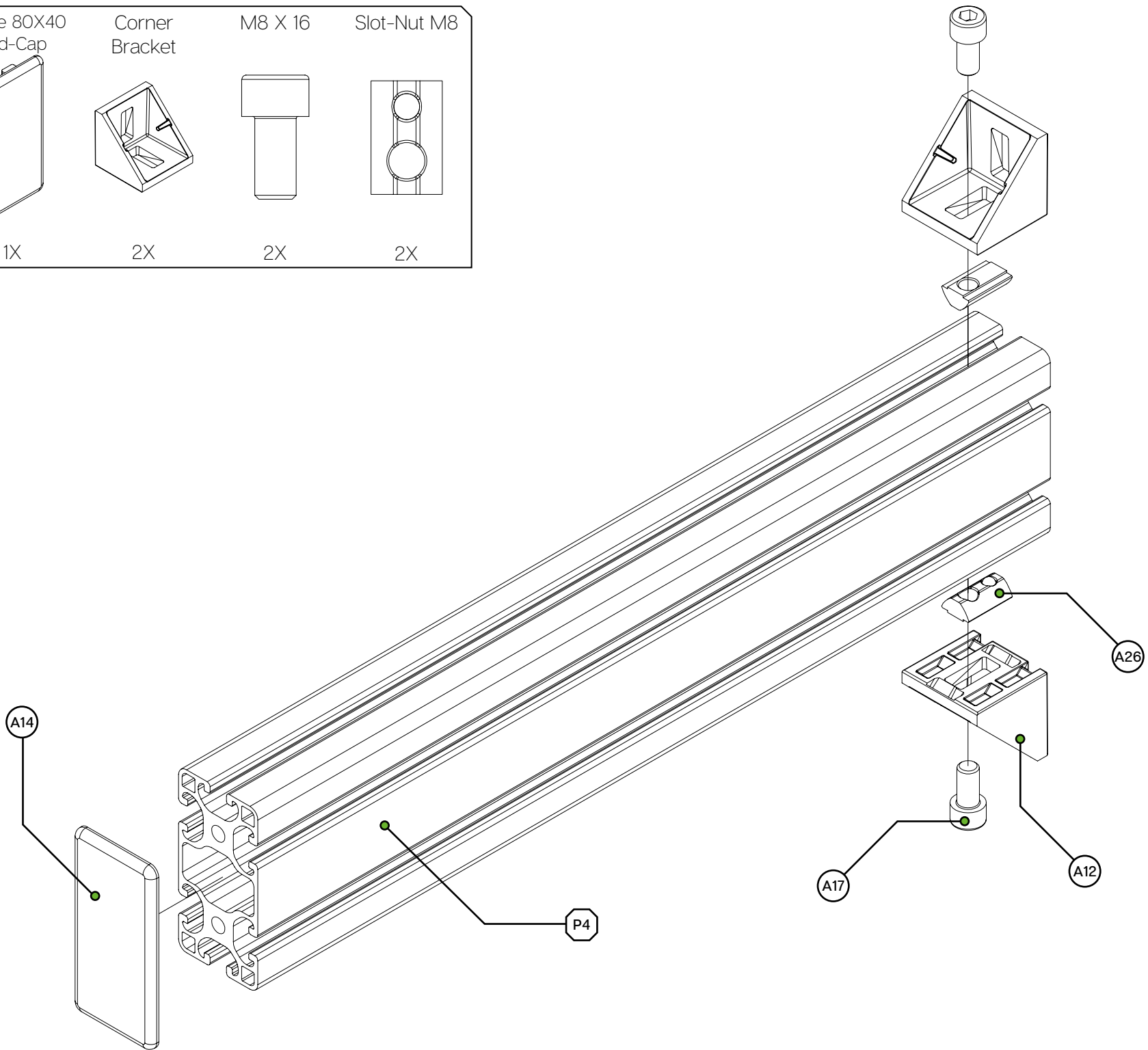
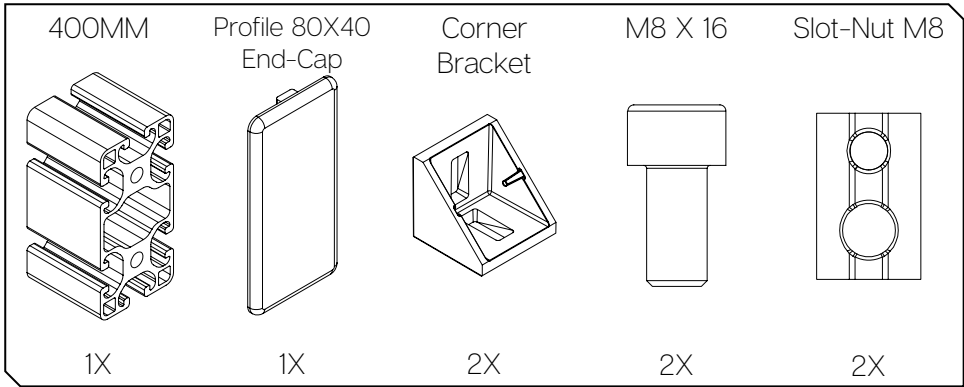

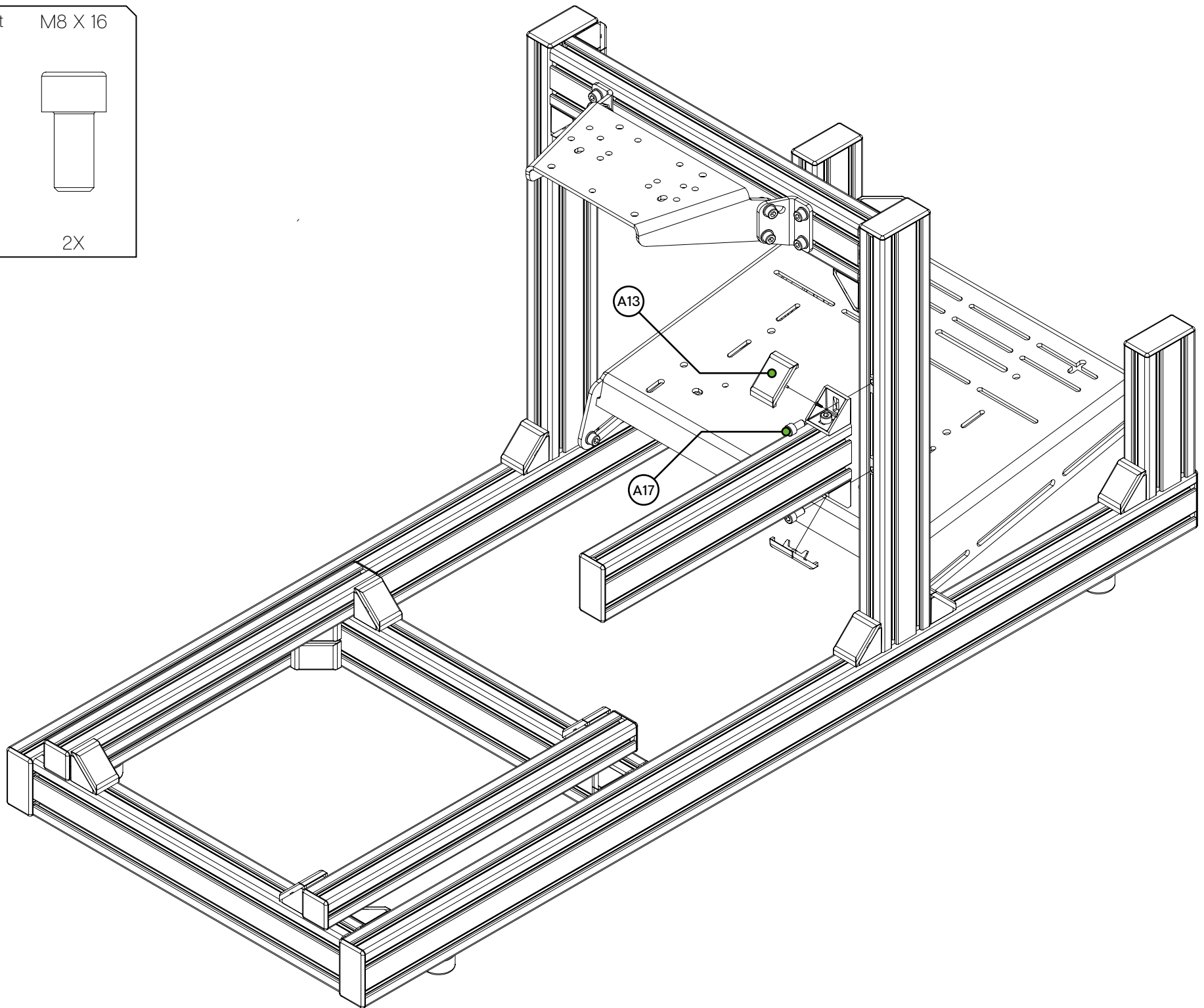
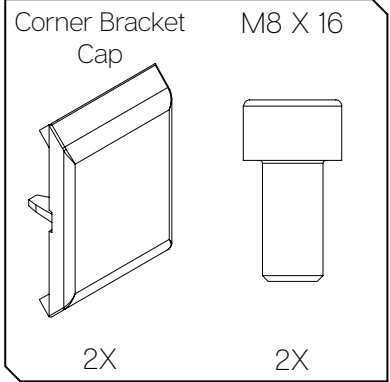

<b>PROFILE KIT</b>			
<b>#</b>	<b>Part</b>	<b>QTY</b>	<b>Note</b>
P1	80X40 Length=1350mm	2	
P2	80X40 Length=580mm	2	
P3	80X40 Length=500mm	3	
P4	80X40 Length=400mm	1	
P5	80X40 Length=200mm	2	
P6	40X40 Length=500mm	2	
<b>HARDWARE KIT</b>			
A7	Pedal deck	1	
A8	Wheel deck plate	1	
A9	Wheel deck pivot plate LEFT	1	
A10	Wheel deck pivot plate RIGHT	1	
A11	Rubber Feet	4	
A12	Corner bracket 40x40	28	
A13	Corner bracket 40x40 cap	28	
A14	Profile 80x40 end-cap	9	
A15	Profile 40x40 end-cap	4	
A16	Bolt M8 X 20 DIN 912	8	Bag HW 20.D
A17	Bolt M8 X 16 DIN 912	72	Bag HW 20.C
A18	Bolt M8 X 12 DIN 912	4	Bag HW 20.D
A19	Bolt M6 X 20 DIN 912	20	Bag HW 20.D
A20	Bolt M6 X 16 DIN 912	10	Bag HW 20.D
A21	Bolt M5 X 25 DIN 912	12	Bag HW 20.D
A22	Washer M8 DIN 125-A	12	Bag HW 20.D
A23	Lock-Nut M8 DIN 985	8	Bag HW 20.D
A24	Lock-Nut M6 DIN 985	12	Bag HW 20.D
A25	Lock-Nut M5 DIN 985	12	Bag HW 20.D
A26	Slot-Nut M8	75	Bag HW 20.B
A27	Slot-Nut M6	12	Bag HW 20.A
<i>Disclaimer: for some entries on this list, we supply more than required as spare materials. Don't worry if you have some leftovers, this is intentional.</i>			

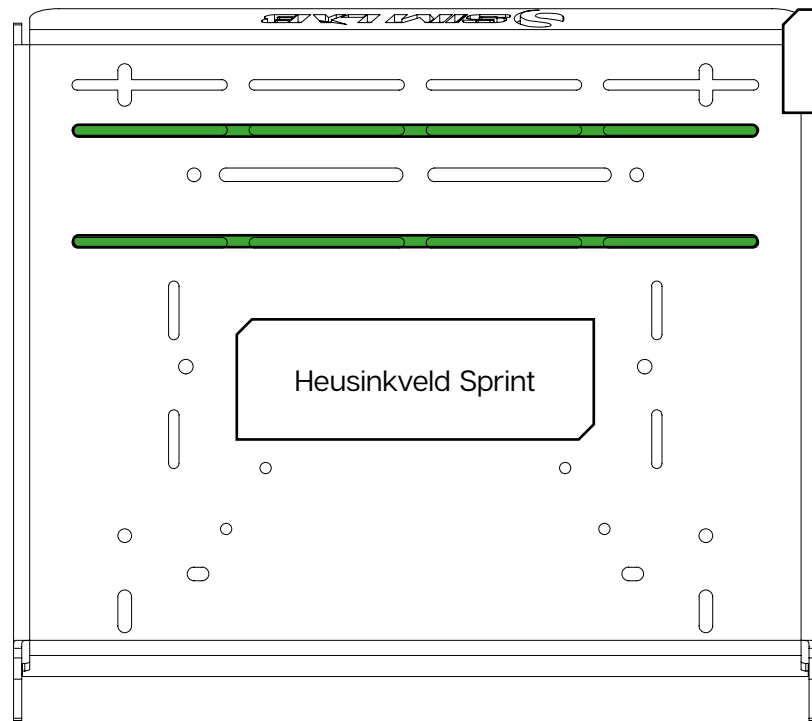
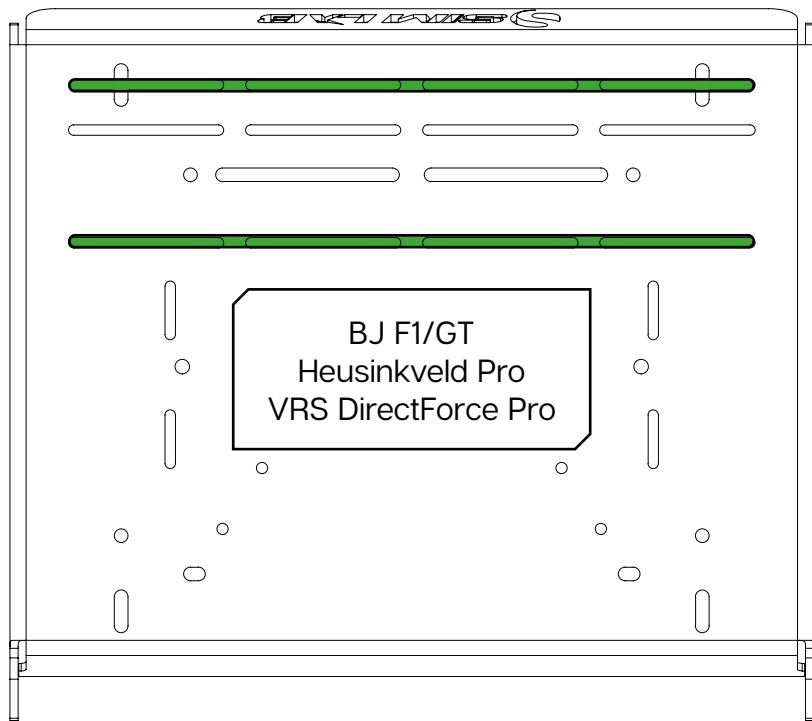

COMPATIBLE  
PEDALS

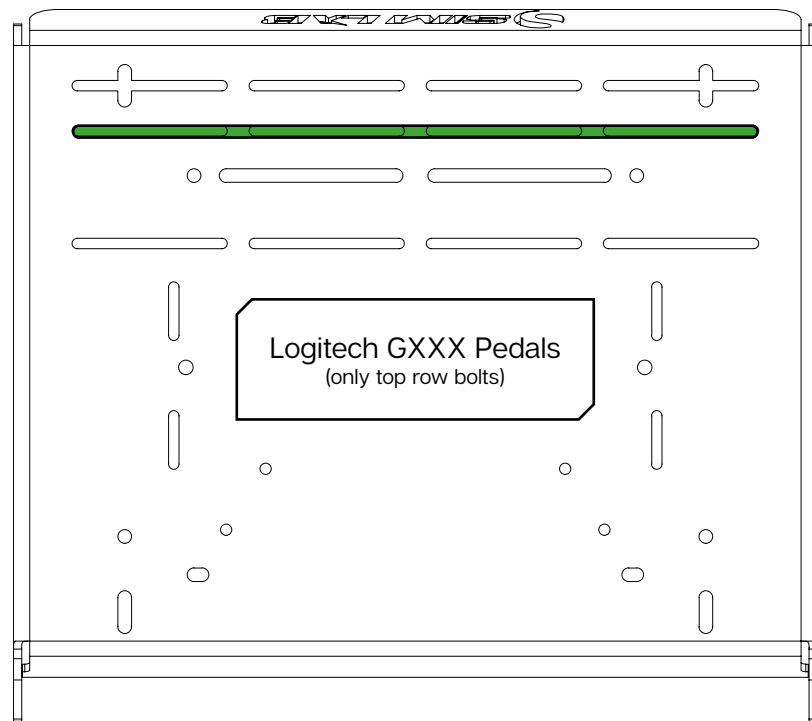
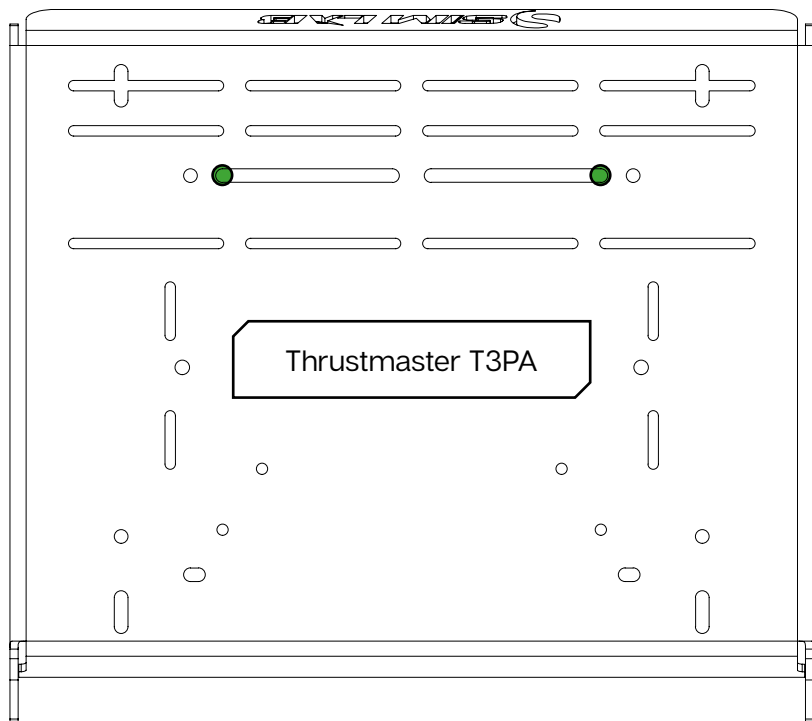

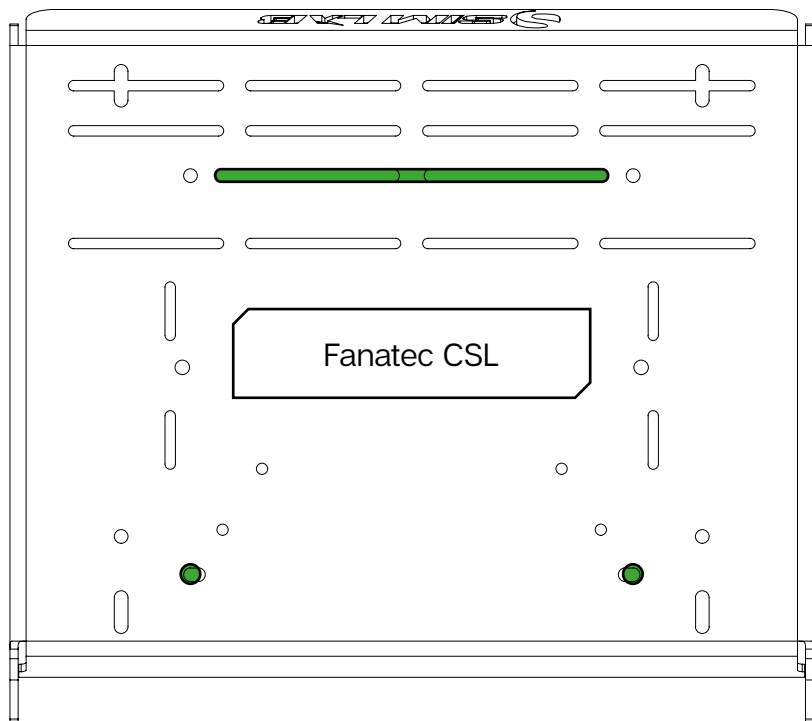
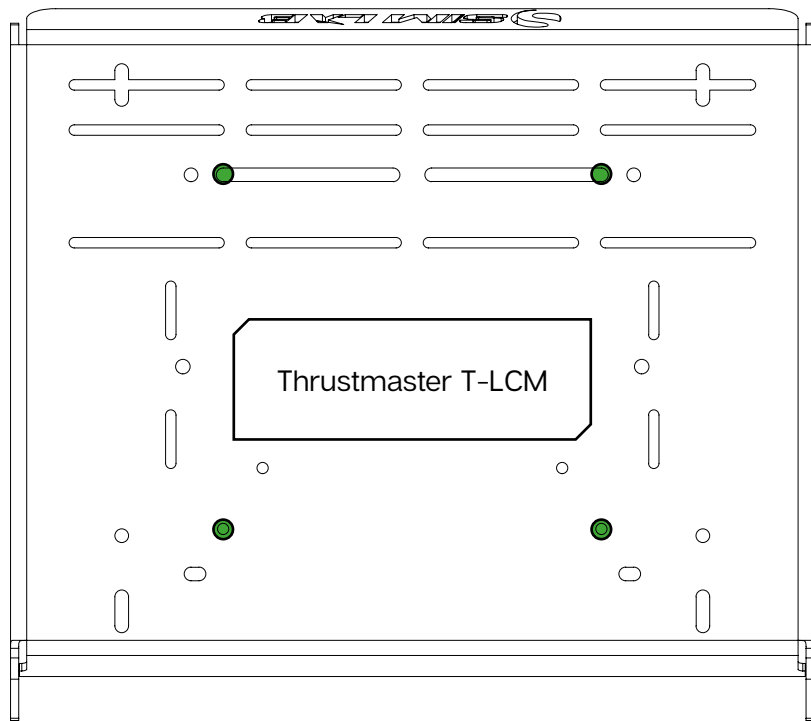
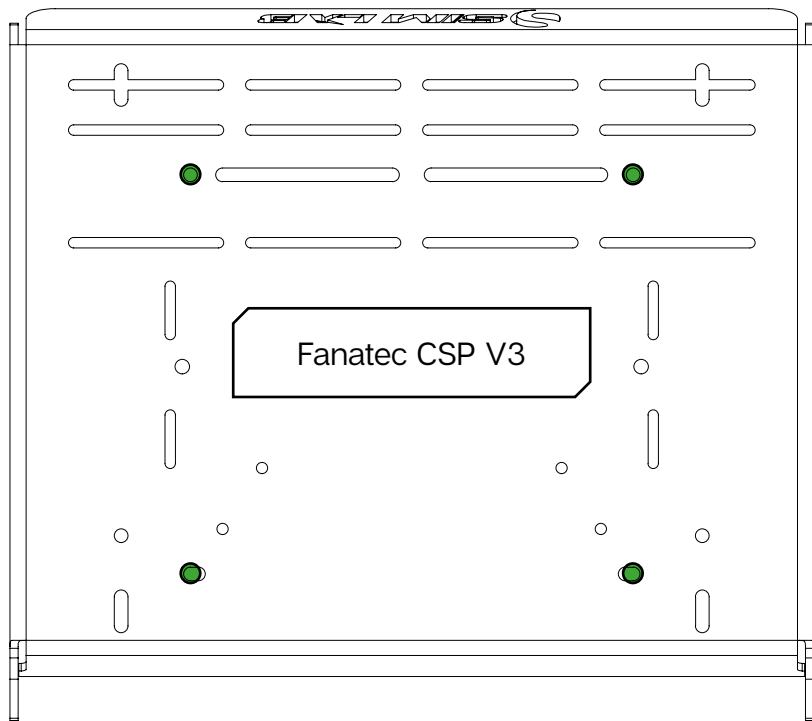



If you still have some questions regarding assembly of this product or about the manual itself, please refer to our support department. They can be reached at

support@sim-lab.eu

Alternatively, we now have a Discord server where there are quite some experienced Sim-Lab customers hanging out. They might just help you along if you ask them nicely ;)

[www.sim-lab.eu/discord](http://www.sim-lab.eu/discord)

If you feel like printing this manual, please consider the environment before doing so. For the best results, make sure you print at 100% scale without borders.

[Product page on the Sim-Lab website:](#)



[Instruction video on YouTube:](#)

