

## Mounting the TK Verano Seat to the TK Falcon Racing Rig

1. Place the seat slider rails on the orange brackets making sure the prong mechanisms are facing inward towards each other and the moving part is facing the front. In the rear, align the second hole on the rounded side of the seat sliders with the single slot on the orange brackets. Fasten a bolt to each, snug but not fully tightened – You will need to center the distance between the brackets when mounting the seat in step 4.

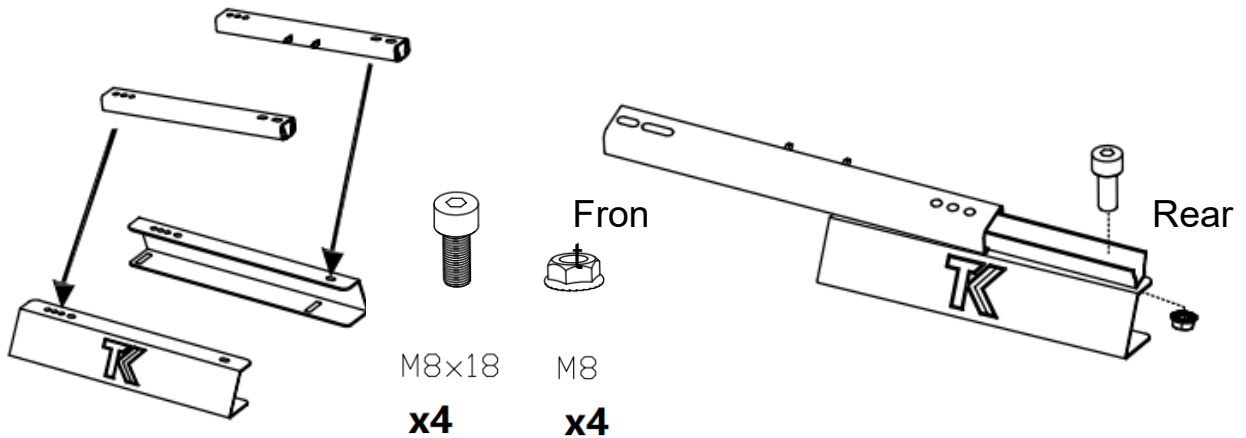

By engaging the lever mechanism with your thumb (use provided gloves to avoid mess and risk of injury), push the seat rails all the way forward on the slider to fasten the rear bolts, and all the way back to fasten the front bolts.



Take your time to make sure everything is straight and square, ensuring that the front holes line up on both the brackets and the sliders. Insert the remaining 2 bolts and fasten snug.

2. Using the smaller of the two blue levers included in the box, and will need to bend (pull apart) the two arms to be a little wider than the distance between the Seat Slider rails.

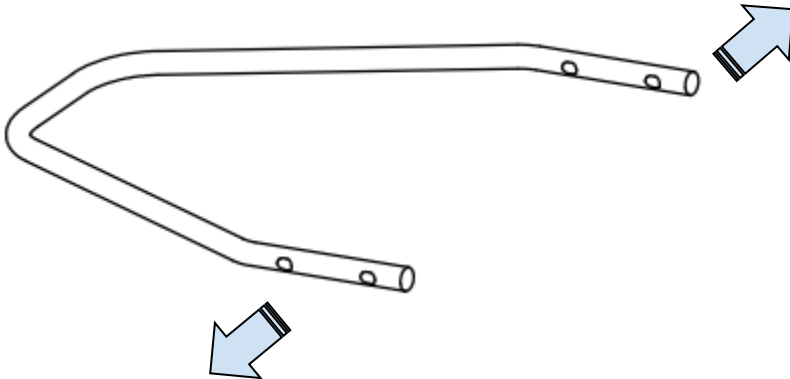

You will also need to bend the tips of each arm back towards each other (A) (to be parallel after spreading) as well as symmetrically on a vertical axis (B) (if looking at the Slider Lever horizontally). You can insert the end of each arm (one at a time) into the open tubular frame of the Falcon Racing Rig up to the existing bend (marked in red in the image) and stand on the frame to provide leverage. You only need to bend it so much to provide enough clearance when you pull up on the bar that will engage the prong mechanisms (about 20 degrees).

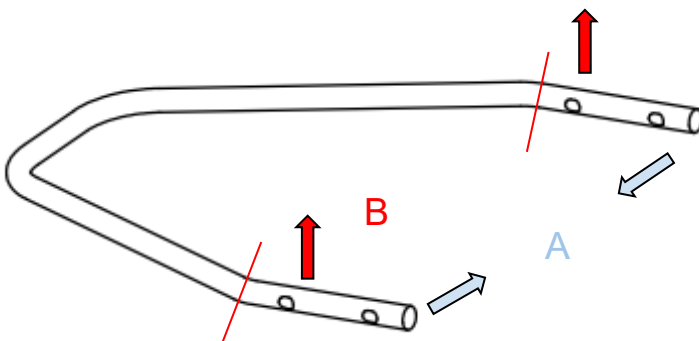

3. You can now slot the prong mechanisms into each end of the Seat Slider Lever. There should be some resistance and the need to compress the Seat Lever by hand.

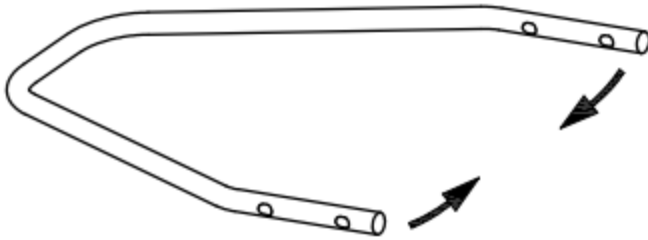

Please be careful not to pinch your hands, work gloves may provide some protection.



4. Unscrew the 4 screws (or bolts) in the bottom of the seat if they are pre-installed. Ensuring that the moving lever of the prong mechanism on the seat sliders are facing the rear of the seat, mount the seat sliders that came with the Verano Seat to the bottom of the seat using the same screws or bolts. Mount the front ends first in the second hole. Make sure the prong mechanisms are facing inward towards each other. The protruding prongs will be what you mount the blue Seat Slider Lever to.

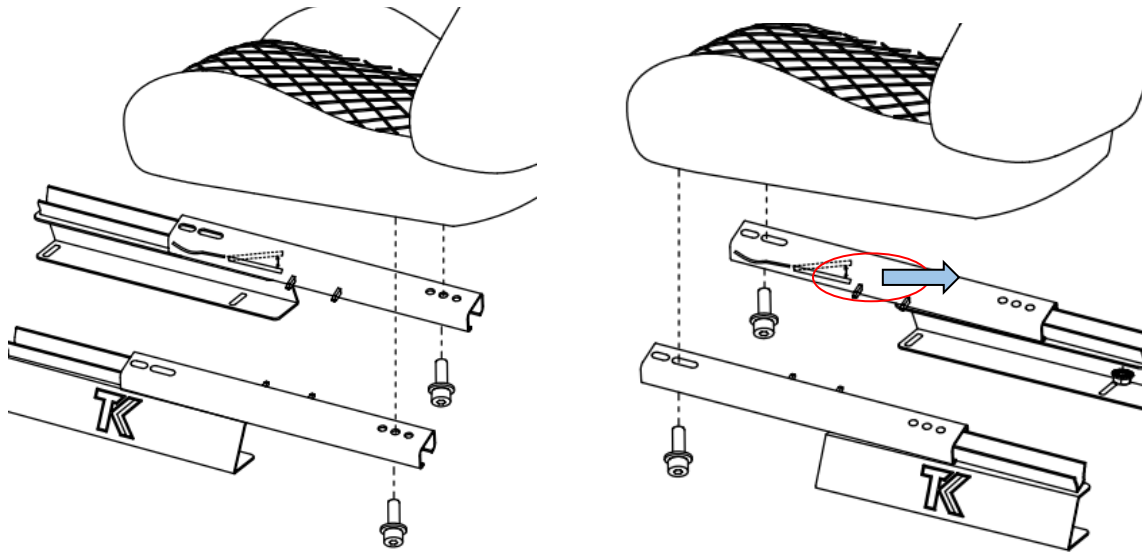

5. Fasten the orange seat brackets (TK facing out, reading left to right) to the flatter half of the rig. Mount the back of each bracket first with a washer (If included) above the bracket and a nut underneath the frame for each of the bolts. Try to center the seat before tightening fully.

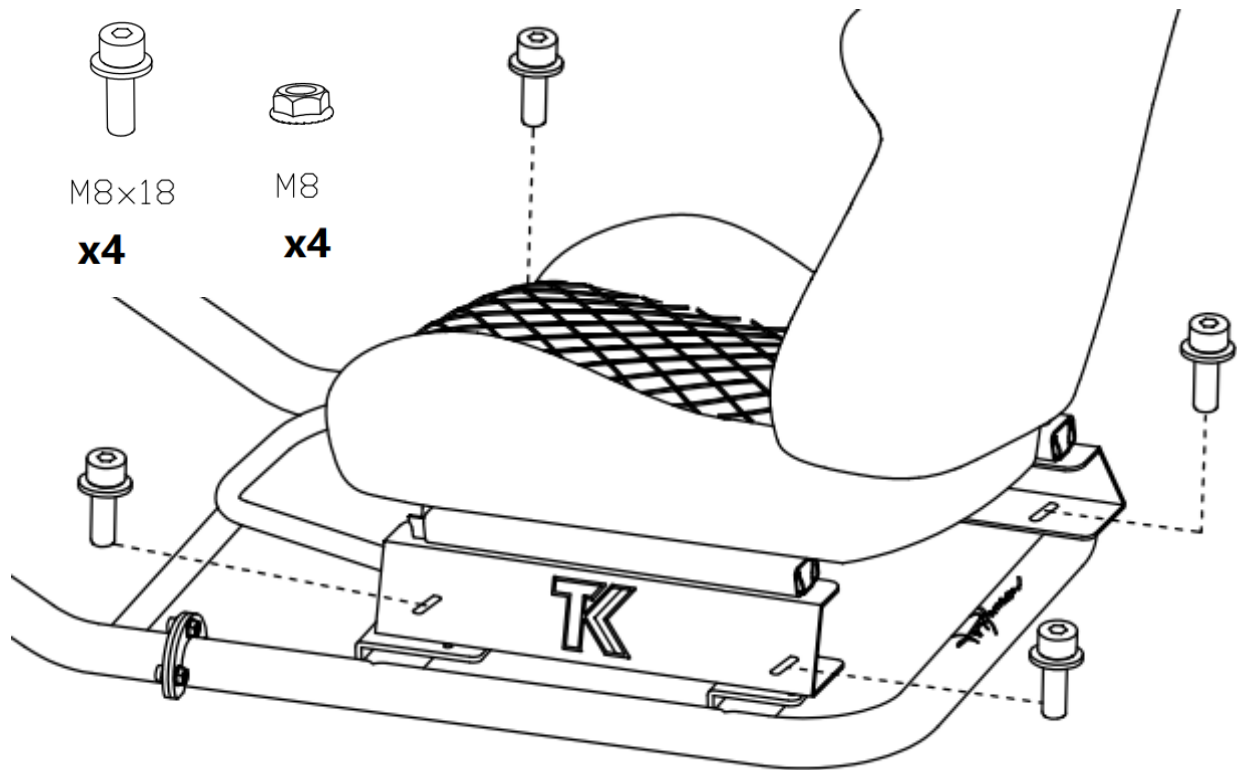

You should be able to center the seat thanks to the long slots on the orange brackets before fully tightening.

You can now mount the seat back to the base. Unscrew the 2 bolts on either side of the back of the seat then place the seat back in between the flanges at the back of the seat base. One side will slide in, while the other one moves. It doesn't matter which side you fasten first, choose whichever is easier for you.

Take the plastic covers and the small screws from the hardware bag in the Verano Seat packaging and fasten them using the small hole in the center of the flanges. **DO NOT OVERTIGHTEN.** Once it feels slightly resistant, stop. overtightening will cause the bolt to eat right through the plastic.

Congratulations, you have just mounted your TK Verano Racing Seat to your TK Falcon Racing Rig.

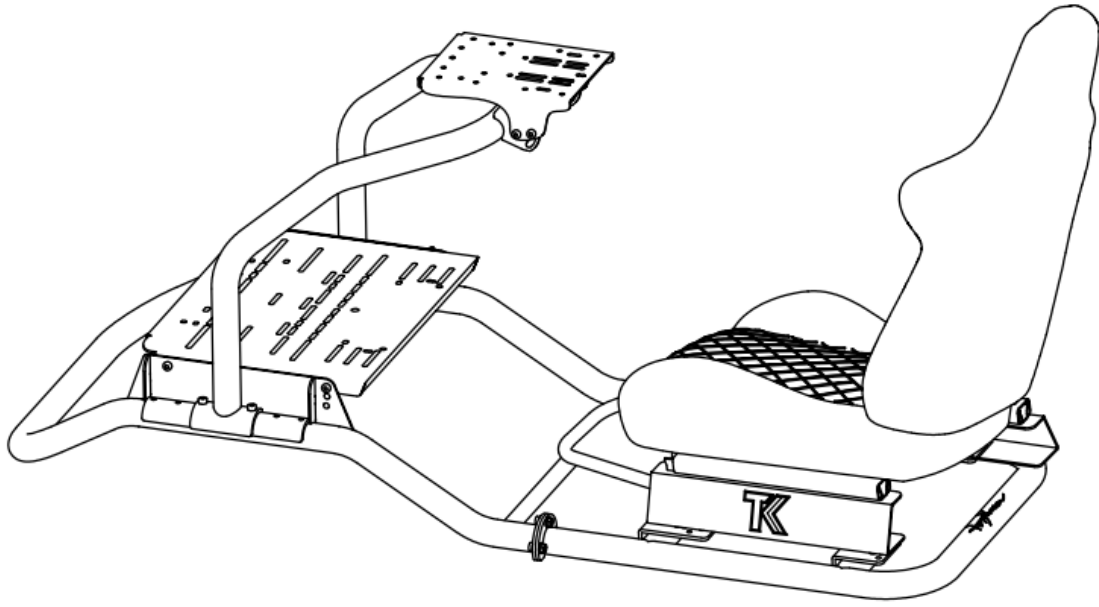

*Korfanon*